



# Aramark Countertop and Refresh Centers

## MANUAL



Waterlogic Commercial Products, LLC  
3175 Bass Pro Drive – Grapevine, TX 76051  
(800) 288-1891      www.waterlogic.us  
Tech Portal Website: [aramark-portal.waterlogic.com](http://aramark-portal.waterlogic.com)

Aramark Headquarters: 1101 Market Street – Philadelphia, Pennsylvania 19107

## **ARAMARK COUNTERTOP AND REFRESH CENTERS MANUAL**

Congratulations on your choice of the **Aramark** water treatment system. The **Aramark Countertop and Refresh Centers** dispense cold, and hot water. The 12-RCPC-1 dispenses cold water only. Every **Aramark Water Treatment System** includes:



**Bio-Cote Anti-Microbial Protection**



**Advanced In-Tank Ultraviolet (UV) Purification**



**Filter configuration can be optimized for all water conditions**

The **Aramark Countertop and Refresh Centers** provide exceptional quality and great tasting water with every use.

## **INTRODUCTION**

Carefully read and follow all instructions to ensure proper and efficient operation of your **Aramark Countertop and Refresh Center**. Contact **Waterlogic** or an **Authorized Waterlogic Dealer** if you have any questions.

**Waterlogic** and **Authorized Waterlogic Dealers** employ trained service personnel who are experienced in the installation, function and repair of **Waterlogic** equipment. This publication is written for use by these qualified individuals. **Waterlogic** encourages users to learn about products, however, we believe that product knowledge and service is best obtained by consulting **Waterlogic** or an **Authorized Waterlogic Dealer**.

**Waterlogic Water Treatment Systems** should be combined with selected water treatment components to create a system specifically tailored for each application by trained and qualified personnel.

Products manufactured and marketed by **Waterlogic** and its affiliates are protected by patents issued or pending in the United States and other countries.

**Waterlogic** reserves the right to change the specifications referred to in this literature at any time, without prior notice. Changes or modifications not expressly approved by **Waterlogic** could void the warranty and user's authority to operate the equipment.

## TABLE OF CONTENTS

### USER GUIDE

- Safety Alert Symbols ..... 4
- Safety Precautions ..... 4
- Features and Benefits ..... 6
- Certifications ..... 7
- Specifications ..... 8
- Operating Instructions ..... 11
- Warranty ..... 12

### SERVICE GUIDE

- Service Requirements ..... 13
- Hot Tank Principles of Operation ..... 15
- Resetting the Hot Tank Overload (High Limit Safety) ..... 16
- Hot Tank Descaling ..... 18
- LG Compressor Upgrade ..... 20
- Replacement Components (Consumables) ..... 21
- Countertop Drawings and Parts List ..... 22
- Refresh Center Drawings and Parts List ..... 29
- Assembling Single RC-1- ..... 37
- Assembling Double RC-2 ..... 40
- Counter Top Flow Diagram ..... 45
- Refresh Center Flow Diagram ..... 46
- Adjusting Cold Water Set Point ..... 47
- Electrical Schematic ..... 48

### INSTALLATION GUIDE

- Pre-Installation Procedures ..... 49
- Countertop Draining Procedure ..... 53
- Refresh Center Draining Procedure ..... 55
- Installation Instructions ..... 57

### TROUBLESHOOTING GUIDE

- Fault Code ..... 60
- Power Troubleshooting ..... 61
- Dispense Troubleshooting ..... 63
- Cold Water Troubleshooting ..... 75
- Hot Water Troubleshooting ..... 76



## **SAFETY ALERT SYMBOLS**

Read and follow all safety information carefully. The signal words used in this manual are selected as shown below and based on an assessment of the degree of potential injury or damage (severe or minor) and the occurrence of injury (definitely occurs or has the potential to occur) when the warning is ignored:

** DANGER!**

*Indicates a situation which, when not avoided, results in death or severe injury.*

** WARNING!**

*Indicates a situation which, when not avoided, has the potential to result in death or severe injury; and/or severe property damage.*

** CAUTION!**

*Indicates a situation which, when not avoided, results or has the potential to result in minor injury; and/or minor property damage.*

## **SAFETY PRECAUTIONS**

### **Basic safety precautions should be followed, including the following:**

Ensure all Local, State, and Federal Laws and Codes including health and safety guidelines are met when installing **Waterlogic** Equipment. Only qualified service technicians should attempt installation and service of **Waterlogic** Equipment. Always read the entire operating instructions before using the appliance and save these instructions for future use.

** DANGER! *This product can cause death or severe injury if incorrectly operated, installed or maintained. The installation, maintenance, sanitizing and any repair must be performed by qualified persons trained by Waterlogic International or their approved distributors only. Do not remove any panel or cover to protect against electrical shock and exposure to UV radiation.***

** DANGER! **ELECTRICAL SHOCK HAZARD.** *Always use a dedicated and properly grounded outlet. Unit should be protected by ground-fault circuit interrupter (GFCI) or residual current device (RCD) having a rated residual operating current not exceeding 30mA. Use only Waterlogic supplied power cord. Never use extension cords or power strips to connect unit. Do not use if the power supply cord is damaged. Always unplug from power supply prior to servicing.***

** WARNING! **AUTHORIZED USE ONLY.** *This appliance is to be used for its intended purpose as described in this manual and untrained individuals who use this manual assume the risk of any resulting property damage or personal injury. This appliance can't be used by children and persons with reduced physical, sensory or mental capabilities or lack of experience.***

** WARNING! **UV-C EMITTER (UV LAMP).** *This appliance contains a UV-C emitter (UV Lamp). UV-C radiation may, even in little doses, cause harm to the eyes and skin. Unintended use or damage to the housing may result in the escape of dangerous UV-C radiation. Never operate the UV-C emitter if damaged or removed from enclosure. Do not touch or look directly into the faucet.***

- ⚠ WARNING! DO NOT OPERATE IF DAMAGED.** *Unplug and isolate water supply if abnormal conditions exist. Contact Waterlogic or authorized dealer for repair, service, and installation to avoid hazards.*
- ⚠ WARNING! HOT WATER.** *Unit produces Hot Water in excess of 80°C (175°F). Water above 52°C (125°F) can cause severe burns or scalding. Keep unauthorized people and children away from the unit to avoid accidental dispensing of hot water.*
- ⚠ WARNING! CONNECT TO POTABLE WATER SUPPLY.** *This system is to be used for water only and is not intended for use where water is microbiologically unsafe or with water of unknown quality without adequate disinfection before or after the system.*
- ⚠ WARNING! TIP HAZARD.** *Dispenser could tip or fall causing serious injury. Always install unit on a firm, flat, and level surface and secure unit to cabinet, wall, or floor if needed. Never place heavy items on top of unit and never climb, stand, or hang on unit or storage cabinet to prevent injury and damage.*
- ⚠ WARNING! UNIT IS HEAVY. TWO PERSON LIFT REQUIRED.** *Transport unit empty and always use material handling equipment or two people with proper lifting technique to reduce injury risk.*
- ⚠ WARNING! STORE AND TRANSPORT UNIT EMPTY. ALWAYS SANITIZE BEFORE USE.** *The unit must be completely drained before storing to avoid stagnation and reduce microbiological contamination (potential bacterial growth). Always sanitize before use to eliminate any potential microbiological contaminants.*
- ⚠ CAUTION! INDOOR USE ONLY.** *Intended for Household Use. Never expose to direct sunlight, heat sources, or ambient air temperature above 37°C (100°F) or below 2°C (35°F). Install indoors and keep unit away from excessive humidity. Never expose to freezing temperatures. Ensure there is adequate clearance around the unit to allow refrigeration system condenser to dissipate heat. Warmer environments require more clearance around the unit. Minimum clearance around all surfaces of the machine is 2-inches. Installs where the ambient temperature exceeds 27°C (80°F), require a minimum of 4-inches clearance for proper heat dissipation and efficient operation.*
- ⚠ CAUTION! USE A WATER PRESSURE REGULATOR.** *Waterlogic will not be responsible for injury or damage caused by excessive water pressure. Input or feed pressure must be 40 psi to 60 psi. Be aware of any potential pressure surges caused by building/municipal pumping stations.*
- ⚠ CAUTION! USE UV STABILIZED SUPPLY LINES.** *Feed the unit with a potable ambient or cold water supply only. Feed water over 37°C (100°F) can damage the treatment components. Water block devices and external leak detectors are strongly recommended. Locate the unit as close to the water supply and the electrical connections as possible. Locate the unit as close to the water supply and the electrical connections as possible. Immediately isolate or close water supply valve and contact service representative if leak is noticed.*

**Contact Waterlogic for assistance or help finding an Authorized Service Representative.**

## **ARAMARK COUNTERTOP AND REFRESH CENTERS FEATURES AND BENEFITS**

### **Cold and Hot Water**

*Aramark Countertop and Refresh Centers* come standard with Cold and Hot Selections to meet a wide range of customer demands. The **12-RCPC-1** Refresh Center comes standard with our Cold Only Water Version.

### **High Volume Storage and Water Capacity**

Refresh Center Models have 4 liters of Cold Water Capacity and 1.6 Liters of Hot Water Capacity. Counter Top has 2 liters of Cold Water Capacity and 1.6 Liters of Hot Water Capacity.

### **BioCote® Anti-Microbial Protection**

Certain plastic, silicon, and painted surfaces surrounding the dispensing areas and drip tray are infused with an exclusive additive called BioCote®. BioCote® provides an effective barrier against microbes like bacteria and mold, which may cause odors or staining.



### **Large Dispense Area with Recessed Faucet**

8.5 inch dispense height with BioCote® recessed faucet to protect from cross-contamination.

### **Leak Detection**

*Aramark Countertop and Refresh Centers* are supplied with a Sensor in the Leak Tray that halts water supply to prevent overflow and sounds alarm to reduce accident potential.

### **Child Safeguard**

*Aramark Countertop and Refresh Centers* requires the Hot Water dispensing button followed by the Main Dispense for Hot Water, and defaults back to cold selection after 3 seconds of inactivity to prevent accidental dispensing of hot water.

### **Energy Saving Sleep Mode**

Energy Saving Sleep Mode turns off the Hot Tank when no Hot Water is dispensed for 3 hours. Touching the Hot Dispense Button turn the Hot Tank back on. The Energy Saving Sleep Mode can be programmed to be disabled.

### **In-Tank UV Purification**

Industry leading In-Tank UV Purification prevents the growth of bio-film within the Stainless Steel Cold Tank.

### **Auxiliary Port**

Auxiliary Port to feed Coffee Machines or other Appliances on *Aramark Countertop and Refresh Centers*.





## ARAMARK COUNTERTOP AND REFRESH CENTERS CERTIFICATIONS

*Waterlogic s* have been tested, and certified to rigorous NSF and UL Standards. We believe that performance testing and certifications validate *Waterlogic* as a world-leader in s.

### [Aramark Countertop and Refresh Centers Certifications Include](#)



#### UL399 – Certified Drinking Water Cooler

Intertek Labs (ETL) Certified the *Aramark Countertop or Refresh Center* to ANSI/UL 399 Standard for Drinking Water Coolers.



BPA Free - *Waterlogic* tests for BPA and declares that all of its products are Bisphenol-A FREE and contain no harmful BPA plastics.



#### NSF/ANSI-61 – Certified Drinking Water System Components

#### NSF / ANSI 372 – Drinking Water System Components – Lead Content

#### CSA B483.1 - Drinking s

This System has been tested and certified in accordance with NSF/ANSI-61 – Certified Drinking Water System Components, NSF / ANSI 372 – Drinking Water System Components for low Lead Content, and CSA B483.1 - Drinking s by the Water Quality Association (WQA)



#### Energy Star Certified

The *Aramark Countertop or Refresh Center*, has been tested and certified to the Energy Star, a US Environmental Protection Agency (EPA) program that helps our customers save money and protect our climate through superior energy efficiency.

*Waterlogic* is certified to ISO 9001:2015 – Quality Management Systems (certified by Intertek). ISO 9001 is the internationally accepted standard for well managed organizations that have adopted the key quality management principles to its operations to bring consistent quality products and a culture of continuous improvement.



### [Safe Drinking Water Act](#)

*Waterlogic s* conform to the Safe Drinking Water Act (SWDA) “lead-free” amendment effective January 4, 2014.

## MODEL/PART DESIGNATIONS

BRAND NAME	DESCRIPTION	MODEL – PART NUMBER
12-CHCMU3-ARA Counter Top	<b>Counter Top</b> - Cold and Hot	12-CHCMU3-ARA
	F-6002-M-HC-UT-CS-ARM Serial Number Prefix: <b>22</b>	
Refresh Center Single, Stone Top	<b>Refresh Center Single</b> – Stone Top Cold and Hot	12-RC-1
	F-BRST1-FS-HC-UT-BS-ARM Serial Number Prefix: <b>23</b>	
Refresh Center Single, Plastic Top – Cold Only	<b>Refresh Center Single– Plastic Top</b> - Cold Only	12-RCPC-1
	F-BRST3-FS-C-UT-BS-ARM Serial Number Prefix: <b>32</b>	
Refresh Center Single, Plastic Top – Hot and Cold	<b>Refresh Center Single– Plastic Top</b> - Cold and Hot	12-RCP-1
	F-BRST3-FS-HC-UT-BS-ARM Serial Number Prefix: <b>31</b>	
Refresh Center Wide with Cabinet, Stone Top	<b>Refresh Center Cabinet – Stone Top</b> - Cold and Hot	12-RC-2
	F-BRST2-FS-HC-UT-BS-ARM Serial Number Prefix: <b>24</b>	

Models	
<p>12-RC-1 Refresh Center Hot/Cold Single, Stone Top</p> 	<p>12-RC-2 Refresh Center Hot/Cold with Cabinet, Stone Top</p> 
<p>12-CHCMU3-ARA Countertop Hot/Cold</p> 	<p>12-RCPC-1 Refresh Center, Cold, Single, Plastic Top</p> <p>12-RCP-1 Refresh Center, Hot/Cold, Single, Plastic Top</p> 



## SPECIFICATIONS

<u>ITEM</u>	<u>Counter Top</u>	<u>Refresh Center</u>
Water Connection	¼" Quick Connect	
Cold Water Temperature	Cold Water Temperature – Factory Set Point 5°C (41°F) Adjustable - 1.1° - 12.2°C (34° - 54° F.)	
Cold Tank Size	Refresh Center: 4 Liters (1.1 Gallons) Counter Top: 2 Liters (.53 Gallons)	
Hot Water Temperature	85°C (185°F) Factory Set Point	
Hot Water Manual Reset Overload	97°C (206°F)	
Hot Tank Size	1.6 Liters (.42 Gallons)	
Recommended Service Pressure	40-60 psi (275-414 kPa) – Use Pressure Regulator	
Maximum Service Pressure	100 psi (689 kPa) – Use Pressure Regulator	
Rated Service Flow	1.89 Liters per Minute (0.5 gallons per minute)	
Environmental Temperature	2° - 37°C (35° - 100°F)	
UV Lamp	4 Watts	8 Watts
Heater	500 W	
Refrigerant Gas	R134a, 40g, 1.41 ounces	R134a, 65g, 2.29 ounces
R134a Pressures	High (230 psi), Low (90 psi)	



## SHIPPING SPECIFICATIONS

<u>ITEM</u>	<u>Countertop</u>	<u>Refresh Centers *Excludes Stone Tops</u>
Width/Depth/Height	34cm x 37cm x 45cm 13.5" x 14.5" x 17.75" #	34cm x 41cm x 103cm 13.5" x 14.5 x 40.5"
Weight (dry)	19.5 kg (42 pounds)	26.5 kg (58 pounds)

# Counter Top is 17.75 in. tall and may not fit between countertops and cabinets - Check installation to ensure adequate clearance.

## ELECTRICAL SPECIFICATIONS

<b>ELECTRICAL SUPPLY</b>	<b>120V/60Hz, 1PH</b>	<b>15 Amp Service</b>
<b>COMPONENT</b>	<b>POWER (approximate)</b>	<b>AMP DRAW (approximate)</b>
Heater	504	4.2 Amps
Compressor	216	1.8 Amps
UV Lamp System	18	0.15 Amps
<b>Total</b>	<b>738</b>	<b>6.15 Amps</b>

## OPERATING INSTRUCTIONS



The above picture shows front LCD display and control panel for the **Aramark Countertop and Refresh Centers**.

For Cold Water: Press Cold Water Select Button followed by the Dispensing Button within 3 seconds for Cold Water.

For Hot Water: Press Hot Water Selection Button followed by the Dispense within 3 seconds for Hot Water. *This is a Safety Feature to prevent accidental dispensing of Hot Water.*

**NOTE:** Default selection mode is Cold Water. Selection will turn to default after 3 seconds of inactivity to prevent accidental dispensing of Hot Water.

**NOTE:** Selection indication light will turn Red when the Hot Water Select Button is pressed, and will switch back to the default green within 3 seconds after dispensing the Hot Water.

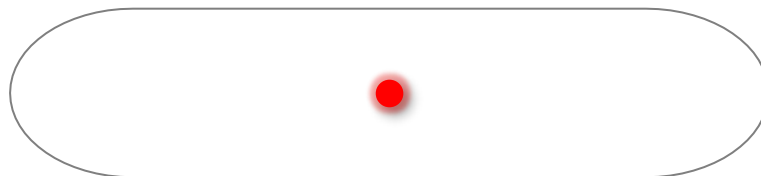



## **WATERLOGIC MANUFACTURED LIMITED WARRANTY** **UNITED STATES AND CANADA ONLY**

*Waterlogic s are guaranteed to the original purchaser to be free of defects in materials and workmanship for a period of three (3) years from the date of purchase, but in no event longer than forty-eight (48) months from the date of manufacture. Waterlogic Commercial Products, LLC (“Waterlogic”) based in the U.S.A. and its affiliated companies are not liable for any cost of removal, installation, transportation, or any other charges which may arise in connection with a warranty claim.*

*This warranty does not cover damage or wear to products caused by abnormal operating conditions, accident, abuse, misuse, unauthorized or improper alteration or repair, damage caused by or resulting from shipping or accident, damage caused by hot water, freezing, flood, fire, or acts of God. The effects from chlorine corrosion, scaling and normal wear are specifically excluded from this warranty. This warranty does not cover products used outside the countries where the unit was purchased, and does not cover products that were not installed in accordance with Waterlogic printed installation and operating instructions obtained in training or from [www.waterlogic.us](http://www.waterlogic.us). Failure to follow all instructions for operation and maintenance voids the warranty. This warranty is not transferable.*

*To obtain warranty repairs or replacement, you must obtain a Return Authorization from Waterlogic. To obtain a Return Authorization, you must submit a Return Authorization form with supporting documentation to Waterlogic for evaluation. The form is available at [www.waterlogic.us](http://www.waterlogic.us). Supporting documentation must include, but is not limited to; proof of purchase, installation date, failure date, and supporting installation and maintenance data. After you submit a Return Authorization form and supporting documentation, Waterlogic will determine whether a reasonably apparent defect in materials or workmanship covered by this limited warranty exists. If Waterlogic determines the claimed defect is covered by this warranty, Waterlogic will, at its sole discretion, determine whether to correct the defect or replace the unit, free of charge to you. If Waterlogic determines that the unit should be returned for warranty service, Waterlogic will approve of return in writing and will issue a Return Authorization which you must obtain prior to shipping the product. You are responsible for the cost of freight in to Waterlogic.*

*Waterlogic and its affiliated companies hereby limit the duration of any and all implied warranties to a maximum period of three (3) years from the date of purchase including, but not limited to, the implied warranties of merchantability and fitness for a particular purpose. Some states do not allow limitations on how long an implied warranty lasts, so the above limitation may not apply to you. Consequential and incidental damages are not recoverable under this warranty. Some states do not allow the exclusion or limitation of incidental or consequential damages, so the above limitation or exclusion may not apply to you.*

*This warranty gives you specific legal rights and you may also have other rights which may vary from state to state.*

**New Warranty Policy issued by Waterlogic Commercial Products LLC, USA - January 10, 2014**

**Waterlogic Commercials Products LLC**  
3175 Bass Pro Drive  
Grapevine, TX 76051

**Tel:** (800) 288-1891  
**Website:** [waterlogic.us](http://waterlogic.us)

## SERVICE REQUIREMENTS

**⚠ WARNING!** *Read and understand the contents of this manual before attempting to service Aramark Countertop or Refresh Center. Failure to follow the instructions in this manual could result in death, serious personal injury, or severe property damage. Only trained and qualified technicians should attempt to install, maintain, or service Waterlogic Equipment.*

1. Visually inspect all electrical and water connections for signs of wear or damage.

**⚠ DANGER!** *HIGH VOLTAGE ELECTRICAL HAZARD. Unplug before inspection and service.*

2. **Waterlogic** recommends changing the UV Lamp every 12 months.

**NOTE:** When replacing the UV Lamp Assembly <sup>\*</sup>, the UV Lamp wiring harness must also be replaced.



**NOTE:** The Glow Starter shown to the right may appear blackened which is normal.

<sup>\*</sup> If the Water Treatment System has an S2 Starter, it is fully interchangeable with the UV Lamp with Glow Starter.

### Switching from S2 Starter to existing Glow-Starter UV Lamp Assembly Instructions

UV Lamp Assembly with S2 Starter:  
Not available as a repair part

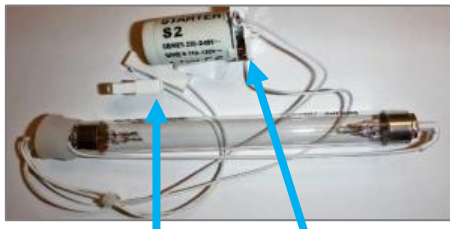

UV Lamp Connectors

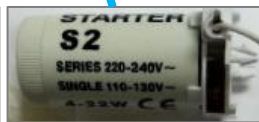

S2 Starter

UV Lamp Assembly with Glow Starter Part #'s:

4-Watt Bulb 12-2350 (CT-2084)

8-Watt Bulb 10-2350 (CT-2083)

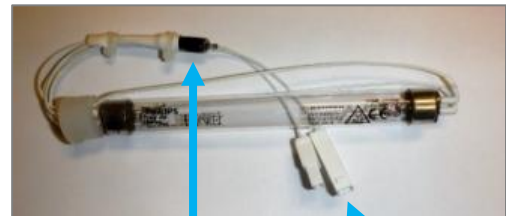

Glow Starter



UV Lamp Connectors

- A. Disconnect Lamp Male and Female Connection Clips from Ballast.
- B. Remove the S2 Starter by pulling upwards.
- C. Remove UV Lamp.

- D. Install Glow Starter UV Lamp.
- E. Connect UV Lamp Male and Female Connection Clips to Ballast.

**⚠ WARNING! ULTRAVIOLET RADIATION.** *Protect your skin and eyes against ultraviolet rays. Never look directly at an operating UV light. Disconnect before removing UV Lamp.*

**⚠ CAUTION! UV LAMPS ARE HAZARDOUS.** *Lamps are considered Hazardous Waste and must be disposed of accordingly. Refer to Product MSDS sheet for details.*

3. Clean the quartz sleeve that surrounds the UV lamp with a non-abrasive cloth, descaling solution, or ultrasonic bath if needed when changing UV lamps.

**⚠ CAUTION! UV SYSTEM IS FRAGILE.** *Never handle the UV lamp or Quartz Sleeve with bare hands. UV Lamp and quartz sleeve must be free of oils and contaminants to ensure proper operation. Use a soft non-abrasive cloth to clean.*

4. Inspect the Quartz Sleeve O-ring for wear or damage and replace as necessary.
5. Ensure there is adequate (minimum of 2”) clearance around the **Aramark Countertop or Refresh Center** and clean the condenser grill and compressor fan to provide efficient cooling system operation.
6. Sanitize the cold tank per instructions in the pre-installation procedures.
7. Clean and sanitize external surfaces of the **Aramark Countertop or Refresh Center**. Use soap and water or chemicals that are compatible with ABS plastic and will not damage or degrade the product surfaces.
8. Remove and clean the Faucet. Replace as needed.

**⚠ WARNING! SANITIZER MAY CONTAIN HAZARDOUS CHEMICALS.** *Use of proper personal protective equipment such as rubber gloves and eye protection is required.*



## HOT TANK PRINCIPLES OF OPERATION

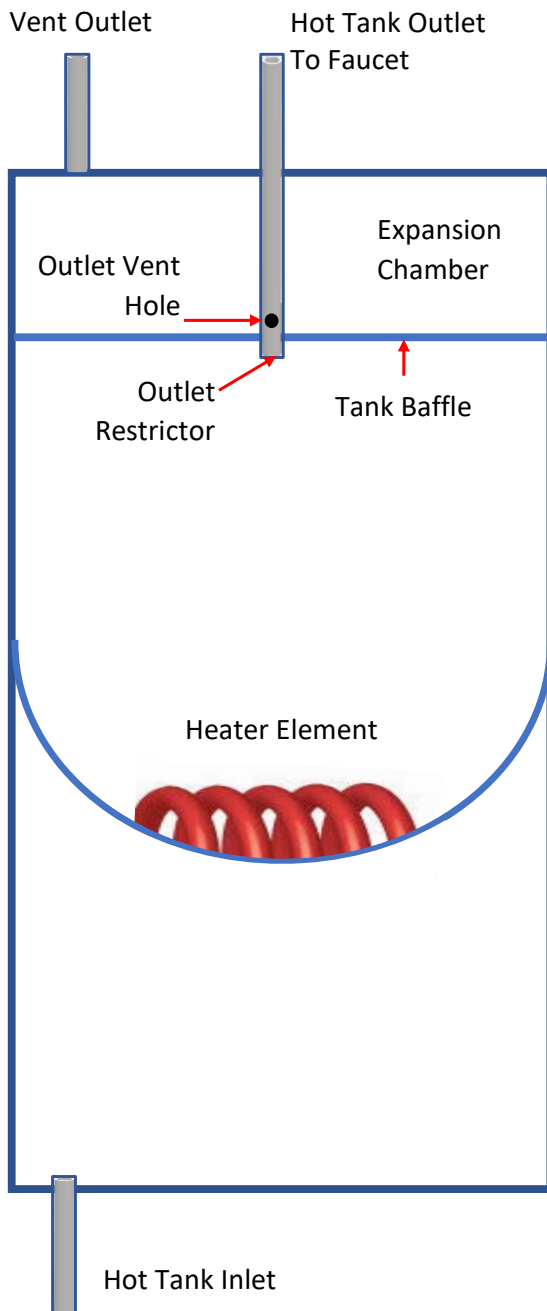

All **Waterlogic** Hot Tanks have a built in Vent or Expansion Chamber in the top of the tank except for WL270 (GF) units.

The Vent Chamber allows for expansion of the water when it is heated.

The chambers are separated by a welded-in tank baffle.

Water always flows into the bottom of the tank and out the top to the faucet.

The hot tank outlet tube has a restrictor in its base. This ensures the reservoir is always full by allowing more water in than out.

There is a small hole in the side of the tank outlet tube that allows air and water to pass into the vent chamber as it is heated.

Water in the vent chamber is suctioned back through the outlet tube vent hole when water is dispensed.



Expansion of water as it is heated in the reservoir will push the water out the faucet when the outlet tube vent hole becomes plugged with debris or scale.



The small Outlet Vent Hole is susceptible to scale build up and is a key indicator that descaling is required.

It is critical to descale the Hot Tank through the vent line and outlet line on a regular basis to prevent this problem.

Descaling through the inlet and/or outlet lines only will not clean the vent chamber and outlet vent hole properly.

## RESETTING THE HOT TANK OVERLOAD OR HIGH LIMIT SAFETY

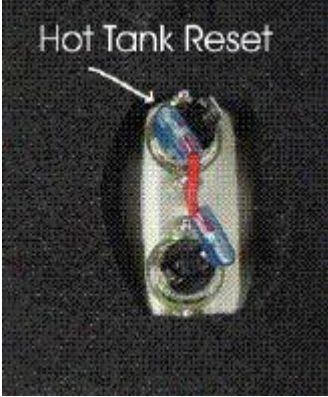
1.	<p>Red Heater and Compressor Switch must be in the OFF position</p> <p><i>O=OFF</i></p> 
2.	<p>Unplug the Power Cord from rear of <b><i>Aramark Countertop or Refresh Center.</i></b></p>
3.	<p>Refresh Center Model: Remove the <u>Lower Front Panel</u> by removing the Phillips Head Screws underneath the Lower Front Panel.</p> <p>Counter Top Model: Remove the <u>Side Panel</u> by removing Phillips Head Screws from Side Panel.</p>
4.	<p>Locate the protective metal box on the rear of the Hot Tank.</p> <p>As you look through the condenser coils on the rear of the unit, you will see the Hot Tank located on the right-hand side.</p> 
5.	<p>Reach up behind the Hot Tank and take hold of the Protective Metal Box covering the Thermostat and Overload on the Hot Tank.</p> <p>There are nuts that secure the metal box to the Hot Tank. However, the nuts are loose enough to allow you to remove the metal box.</p> <p>If the nuts on the metal box are too tight, loosen the nuts securing the Hot Tank to the upper base of the unit and lower the hot tank so you can remove the metal box.</p> <p><i>For demonstrative purposes, photos below have lowered the Hot Tank from the unit.</i></p> 

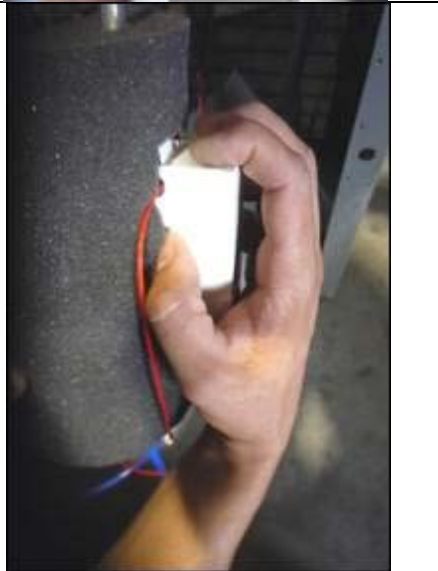
<p>6.</p>	<p>Press the reset button</p>  <p>The image shows a small, rectangular metal component with two blue buttons. One button is labeled 'Hot Tank Reset' with a white arrow pointing to it. The component is mounted on a metal base.</p>	 <p>A close-up photograph showing a person's hand pressing the blue reset button on the metal component. The component is mounted on a dark, cylindrical metal tank.</p>
<p>7.</p>	<p>Reattach the metal box by depressing the top flap of the Metal Box so it snaps back into its original position on the Hot Tank.</p>	 <p>A close-up photograph showing a person's hand holding a metal box and snapping it back onto the hot tank. The box is white and has a top flap that is being depressed.</p>
<p>8.</p>	<p>Replace Panel on unit using Phillips head screws.</p>	
<p>9.</p>	<p>Plug in the Power Cord.</p>	
<p>10</p>	<p>Make sure the Hot and Cold Tanks are filled with water BEFORE turning on the Red Heater and Compressor Switch.</p> <p>Verify the cooler is fully operational before installing it at the customers' site.</p>	

## **HOT TANK DESCALING INSTRUCTIONS**

The Hot Tank requires removal of mineral deposits (descaling) on a regular basis. Typically descaling should take place every 6 to 12 months to preserve the long-term health of your unit.

Use non-toxic cleaner such as ScaleKleen, DEZCAL, 20% Citric Acid Solution, or Undiluted Vinegar Solution to remove mineral deposits as directed by the manufacturer depending upon filtration and local water conditions.

Descaling is an important process that removes calcium deposits, or scale, that can build up inside a tank over time. Calcium and scale is non-toxic but left unattended will hinder your **Aramark Countertop or Refresh Center's** performance.

**⚠ WARNING! PERSONAL PROTECTIVE EQUIPMENT REQUIRED.** Always ensure proper ventilation and use rubber or nitrile gloves and eye protection when using chemicals. Refer to Material Safety Data Sheet for specific requirements of each product.

**⚠ CAUTION! STAINLESS STEEL TANK DESCALING.**

*The Hot Tank is made from stainless steel. Ensure descaling solution is compatible with stainless and always flush the **Aramark Countertop or Refresh Center** completely. Dispose in an environmentally safe manner.*

### **Materials Needed:**

- Personal Protective Equipment. Rubber or Nitrile Safety Gloves and Protective Eyewear
  - Phillips Screwdriver
  - Temperature Gauge
  - Water Pitcher or Container to collect water from the faucet
  - 5-gallon container or drain basin
  - Citric Acid Based Cleaner
  - ¼" Plastic Tubing, at least 4 feet in length, and assorted ¼" quick connect fittings
  - Sanitizing Cartridge
  - Food Coloring
1. Put descaler per directions and 3 drops of food coloring into the descaling cartridge.
  2. Connect descaling cartridge to the inlet water supply and connect to inlet bulkhead fitting on the back of the **Aramark Countertop or Refresh Center**. Turn on Water Supply.
  3. Select Hot Water and depress the Main Dispensing Button on the Front Control Panel until descaling solution (colored water) comes out of the faucet. Container and drain basin will be required to catch water from the faucet.
  4. Turn off water supply and remove sanitizing cartridge from inlet water supply. Reconnect water supply to inlet fitting.

5. Allow descaling solution to remain in the Hot Tank for 15 minutes (length of time may vary depending on water conditions).
6. Place a pitcher, catch basin or other container under the faucet of the ***Aramark Countertop or Refresh Center***.
7. Flush the Hot Tank until water runs clear.
8. Once clear Water dispenses from the faucet the Hot Tank has been descaled. Always ensure the ***Aramark Countertop or Refresh Center*** is performing to the customer's satisfaction.

**⚠ WARNING! HOT WATER HAZARD.** The ***Aramark Countertop and Refresh Centers produce Hot Water up to 86°C (187°F)***. Water above 52°C (125°F) can cause severe burns or scalding. Hot water should be dispensed carefully into insulated container to avoid injury.

**⚠ CAUTION! MUST REPLACE HOT TANK EVERY 3-5 YEARS DEPENDING ON USAGE**  
*The Hot Tank and its controls must be replaced a minimum of every three to five years depending on usage to ensure efficient and dependable operation.*

**⚠ WARNING! REINSTALL ALL PANELS AND COVERS.** Always reinstall all Panels, protective covers, and fasteners after servicing equipment. Failure to do so could result in severe personal injury and will void the certifications and warranty of the equipment.

## LG COMPRESSOR UPGRADE

\*Parts List in this manual updated to reflect these changes.

**New LG Compressor 120V R134A 1/8HP CSB035LJCM with external start/run capacitor.**

### New LG Compressor with External Start/Run Capacitor



**External Capacitor**

New LG CSB035 LJCM Compressor

Repair/Replacement Parts for are not interchangeable with older/other compressors.

Older version of LG compressor is obsolete and no longer available.

### **New LG CSB035LJCM 120V R134A 1/8HP Compressor Repair Parts**

Part # CO-0017-L00-00	LG Compressor 120V CSB035LJCM-PTC Relay
Part # CO-0018-L00-00	LG Compressor 120V CSB035LJCM-Overload Protector
Part # CO-0019-L00-00	LG Compressor 120V CSB035LJCM-Capacitor



## REPLACEMENT COMPONENTS (CONSUMABLES)

Component	WLCP Part No.	Frequency of Replacement
UV Light, 4 Watts Assembly <b>Counter Top</b>	12-2350	Every 12 months, or as required CT-2084
UV Light, 8 Watts Assembly <b>Refresh Center</b>	10-2350	Every 12 months, or as required CT-2083
Hot Tank 1.6 Liter (.42 Gallons) 87°C (189°F) <b>Counter Top</b>	12-1406	Replace every 3-5 years depending on usage HT-3018-A
Hot Tank 1.6 Liter (.42 Gallons) 87°C (189°F) <b>Refresh Center</b>	12-1405	Replace every 3-5 years depending on usage HT-3018
Black Quartz Sleeve O-Ring	10-2500	Each time Quartz Sleeve is replaced CT-2006
GAC Filter - 10" Carbon Activated Inline Filter - <b>Optional</b>	FT-0035	Every 6-months or as required. Local water conditions will determine proper filter type and maintenance schedule. FT-0035-IL-WLT
Carbon Block - 10" CBC 1 Micron Lead and Cyst Reduction Inline Filter – <b>Optional</b>	FT-0063	Every 6-months or as required. Local water conditions will determine proper filter type and maintenance schedule. FT-0063-IL-WLT
Sediment Block - 10" Sediment 20 Micron Inline Filter - <b>Optional</b>	FT-0053	Every 6-months or as required. Local water conditions will determine proper filter type and maintenance schedule. FT-0053-IL-WLT

Replacement parts can be obtained from *Waterlogic* or an *Authorized Waterlogic Dealer*. See Parts Layouts, Drawings, and Lists for additional repair parts.

### Hot Tank Service

Hot Tanks (with controls) must be replaced at least every Replace every 3-5 years depending on usage. Descaling hot tank may be required on a regular basis depending upon filtration and local water conditions. See Service Section.











### NOTE:



At the **end of this product's life**, ensure that it is disposed of in an environmentally friendly manner which is fully compliant **with all Federal/State/Local Requirements and Guidelines**.



No	WLCP Part No.	Description	Part No	Stocked?	
<b>Consumables</b>					
1	12-2350	4W Lamp Assembly	CT-2084	Yes	
2	12-1406	Hot Tank 1.6 Liter (.42 Gallons) 87°C (189°F) – Counter Top <i>Recommend stocking 2 each per every 10 units purchased</i>	HT-3018-A	Yes	
Not Shown	FT-0035	GAC Filter - 10" Carbon Activated Inline Filter – <b>Optional</b>	FT-0035-IL-WLT	Yes	
Not Shown	FT-0063	Carbon Block - 10" CBC 1 Micron Lead and Cyst Reduction Inline Filter – <b>Optional</b>	FT-0063-IL-WLT	Yes	
Not Shown	FT-0053	Sediment Filter - 10" Sediment 20 Micron Inline Filter – <b>Optional</b>	FT-0053-IL-WLT	Yes	
<b>Recommended Spare Parts</b>					
2.1	12-1360	Overload with Manual Reset - 97°C (206°F) <i>Recommend stocking 2 each per every 10 units purchased</i>	HT-3012	Yes	
2.2	12-1303	Hot Tank Thermostat - 87°C (189°F) <i>Recommend stocking 2 each per every 10 units purchased</i>	HT-3013A	Yes	
2.3	12-6900	Thermostat and Overload Metal Cover <i>Recommend stocking 2 each per every 10 units purchased</i>	ST-8290	Yes	
3	10-2500	Black O-Ring for Quartz Sleeve <i>Recommend stocking 1 each per every 10 units purchased</i>	CT-2006	Yes	
4	14-1051	Quartz Sleeve for 4W Lamp <i>Recommend stocking 1 each per every 10 units purchased</i>	CT-2026	Yes	
5	12-1500	Solenoid Valve 1000 mm <i>Recommend stocking 2 each per every 10 units purchased</i>	PU-4016	Yes	
5.1	CU-0001	Solenoid Cushion <i>Recommend stocking 2 each per every 10 units purchased</i>	CU-0001	Yes	



6	10-3010	UV Lamp Ballast 110V/60Hz <i>Recommend stocking 2 each per every 10 units purchased</i>	EL-5006-A CN	Yes	
7	12-3135	Silicon Button Key Mat <i>Recommend stocking 5 each per every 10 units purchased</i>	PL-1239-CN	Yes	
8	12-8057	Button Label <i>Recommend stocking 2 each per every 10 units purchased</i>	LP-7084	Yes	
9	12-3140	Drip Tray Grill – Silver <i>Recommend stocking 4 each per every 10 units purchased</i>	PL-1242-CN	Yes	
10	12-3130	Drip Tray - Charcoal with Aramark Logo <i>Recommend stocking 4 each per every 10 units purchased</i>	PL-1237-CN	Yes	
Not Shown	10-3048	Faucet Nipple – Blue with Screen <i>Recommend stocking 2 each per every 10 units purchased</i>	PL-1013	Yes	
Not Shown	10-2600	Natural Faucet O-Ring – Silicon White <i>Recommend stocking 2 each per every 10 units purchased</i>	CT-2007	Yes	
Not Shown	01-2076	ScaleKleen <i>Recommend stocking 2 each per every 10 units purchased</i>	NA	Yes	
<b>Remaining Parts</b>					
11	12-3145	Flat Top Cover - Charcoal with Texture	PL-1242-B	Yes	
11.1	NA	Metal Cover (Under Top Cover)	ST-0049-L00-00	Yes	
12	10-8085	UV Lamp Fixing Rubber	CT-2001-B	Yes	

13	12-1210	UV Lamp Retaining Threaded Nut	PL-1128	Yes	
14	12-3165	Upper Shelf	ST-8150	Yes	
Not Shown - on Top Shelf	12-8510	UV 3minutes Timer PCB - Hot and Cold	AK-0008-A	Yes	
Not Shown - on Top Shelf	NA	3minutes UV Timer PCB Fixing Bracket	ST-8287	No	
15	12-3110	2L UV Cold Tank Assembly	CT-2060	Yes	
16	12-3185	Side Panel – Silver	ST-8241	Yes	
17	12-3120	Front Upper Drip Tray Insert Panel – <i>when purchasing, also request Hot Water Caution Label KB-11 to adhere to front of this panel.</i>	PL-1201-CN	Yes	
17.1	KB-11	Hot Water Caution Label – <i>adhere to Front Upper Drip Tray Insert Panel.</i>	NA	Yes	
18	12-3160	PCB Cover	PL-1298	Yes	
19	12-3115	PCB for Hot and Cold for Leak Detection System	EN-6085-A	Yes	
19.1	10-3017	PCB Stand-off Pin	EN-6059	Yes	



20	12-3125	Front Hatch Panel Charcoal with UV logo <i>Sold Separately: Button Label (P/N 12-8057) &amp; Silicon Button Key Mat (P/N 12-3135)</i>	PL-1236-L00-SI	Yes	
21	10-2700	Faucet Assembly	PL-1011	Yes	



**Verify compressor in machine before ordering parts as the Compressor P/N CO-0020-L00-00 and 10-2200 (CO-0001A) and related parts are not interchangeable.**

### CO-0020-L00-00 Compressor



22A.1	CO-0020-L00-00	LG Compressor 120V R134A CSB035LJCM	CO-0020-L00-00	Yes	
22A.2	CO-0019-L00-00	Compressor Capacitor	CO-0019-L00-00	Yes	
22A.3	ST-0216-L00-00	Capacitor Bracket	ST-0216-L00-00	Yes	
22A.4	CO-0017-L00-00	PTC Relay	CO-0017-L00-00	Yes	
22A.5	CO-0018-L00-00	Overload Protector	CO-0018-L00-00	Yes	

### CO-9001-A / 10-2200 Compressor

22B.1	10-2200	Compressor (R134a 1/8HP) 120V/60Hz	CO-9001-A	Yes	
22B.2	10-3003	Compressor Starter Relay	CO-9016	Yes	
22B.3	10-5018	Compressor Overload	CO-9015	Yes	

23	12-3150	Unit Rubber Feet	PL-1251-CN	Yes	
24	12-3170	Bottom Tray	ST-8151	Yes	
25	12-3155	Leak Tray	PL-1294	Yes	



26	12-3180	Leak Containment Tray Clip (sensor 0.5mm)	ST-8207-CN	Yes	
26.1	NA	Leak Sensor Wire	EL-5076-KR	No	
27	12-3175	Filter Bracket	ST-8152	Yes	
27.1	10-3099	3" Filter Clip	PU-4024	Yes	
27.2	10-3098	2" Filter Clip for In-Line Filter	PU-4025	Yes	
28	12-3195	Leak System Inlet Solenoid Bracket	ST-8244	Yes	
29	Purchase from John Guest	JG Equal Tee Connector 1/4"	PU-4011	No	
30	Purchase from John Guest	JG Reducing Elbow Connector 5/16" * 1/4"	PU-4007	No	
31	Purchase from John Guest	JG Equal Elbow Connector 1/4"	PU-4008	No	
32	10-3067	Bulkhead Union 1/4" x 1/4" John Guest P/N PI1208S	PU-4028-A	Yes	
32.1	Purchase from John Guest	JG 1/4" Stopper PI0808S (used with Bulkhead Union 1/4" x 1/4" John Guest P/N PI1208S)	PU-4086	Yes	
33	12-3100	Wire Condenser	CO-9031	Special Order	
33.1	12-1001	Filter Dryer	CO-9008	Yes	

34	10-4013	Power Line Noise Filter, ElectroMagnetic Interference filter (EMI)	EL-5016	Yes	
35	10-3014	Fuse Holder and Fuse 120V / 15A with One Wire	EL-5053	Yes	
35.1	10-3013	Fuse 120V / 15A	EL-5010	Yes	
36	10-3008	Red Compressor and Heater Switch	EL-5004	Yes	
37	12-1101	Cold Tank Thermostat	CT-2016	Yes	
37.1	PL-0326	Cold Thermostat Cover Label	PL-0326-L00-00	Yes	
38	12-8061	Silver Back Panel	ST-8216	Yes	
39	12-3117	Power Transformer 120V	EL-5003-A	Yes	
Not Shown	Purchase from John Guest	JG LLD PE Tube - Blue O.D.1/4" John Guest P/N PE-08-BI-1000F-B	PU-4031-A	No	
Not Shown	10-3062	JG LLDPE Tube - Blue 8mm John Guest P/N PE-0806-100M-B	PU-4014-A	No	
Not Shown	10-7040	Silicon Tube 5/16" for Hot Water	PU-4064	Yes	
Not Shown	10-3007	Power Cord 120V – 1840 mm	EL-5001-B	Yes	

## ARAMARK REFRESH CENTERS DRAWING AND PARTS LIST

Yellow = Consumables

Green = Recommended spare parts

Wetted Drawing

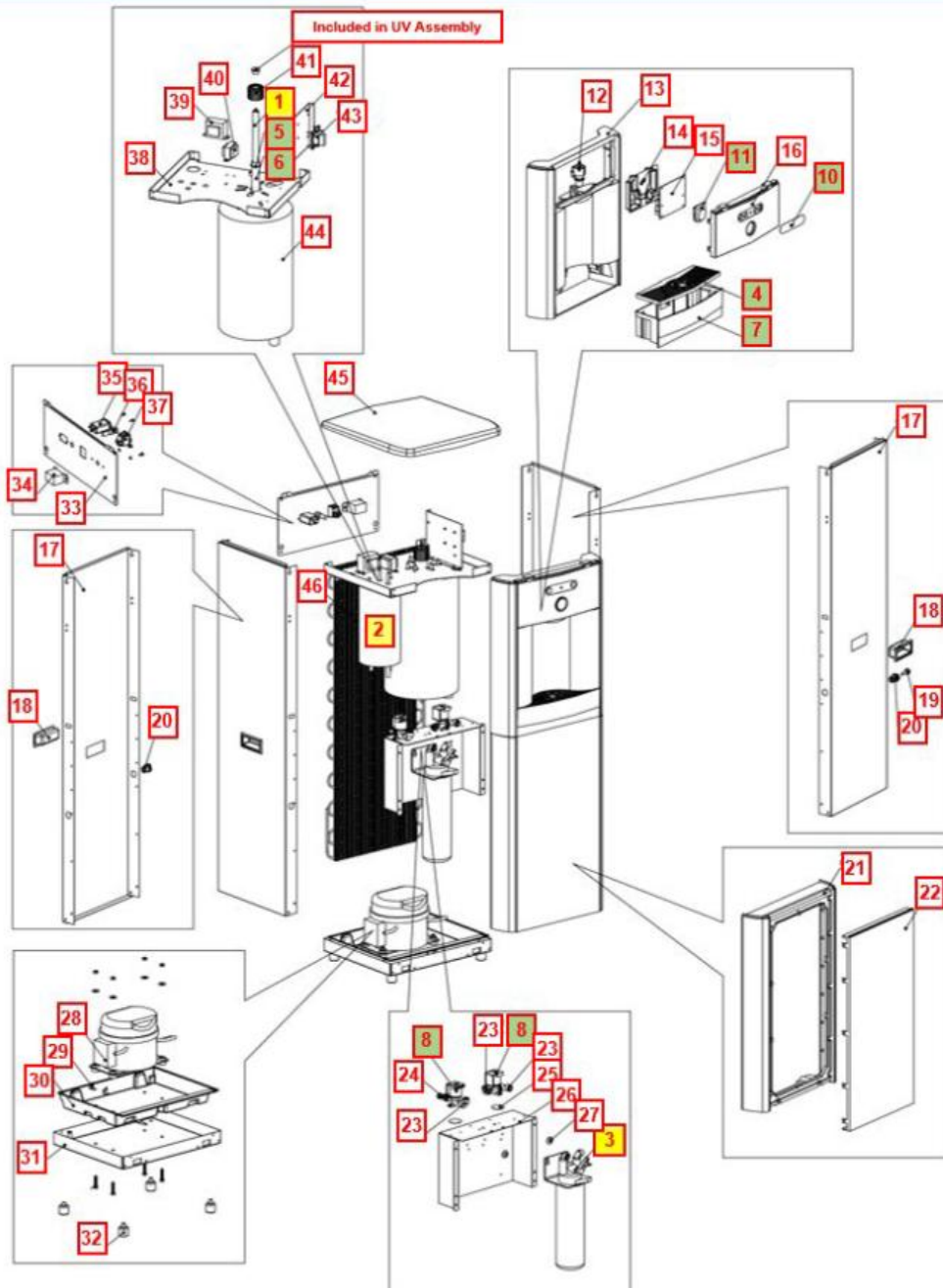
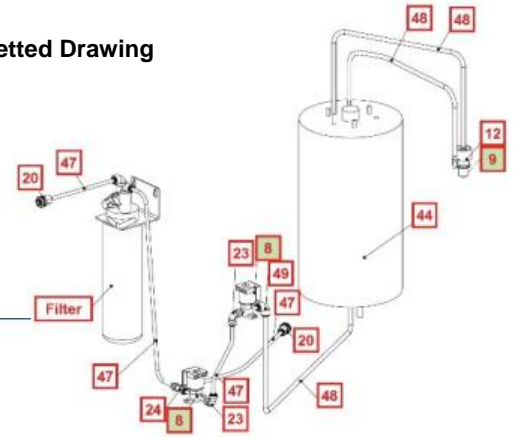







No	WLCP PN	Description	Part No	12-RCPC-1 Plastic Top Cold Only	12-RCP-1 Plastic Top Hot & Cold	12-RC-1 Stone Top Hot & Cold	Stocked?	
<b>Consumables</b>								
1	10-2350	8W UV Lamp Assembly (includes UV Lamp Fixing Silicon Rubber – PN CT-2001-B)	CT-2083	X	X	X	Yes	
2	12-1405	Hot Tank Stainless Steel 1.6 Liter (87°C - 189°F) <i>Recommend stocking 2 each per every 10 units ordered</i>	HT-3018		X	X	Yes	
3	FT-0035	GAC Filter - 10" Carbon Activated Inline Filter – <b>Optional</b>	FT-0035-IL-WLT	X	X	X	Yes	
	FT-0063	Carbon Block - 10" CBC 1 Micron Lead and Cyst Reduction Inline Filter – <b>Optional</b>	FT-0063-IL-WLT	X	X	X	Yes	
	FT-0053	Sediment Block - 10" Sediment 20 Micron Inline Filter – <b>Optional</b>	FT-0053-IL-WLT	X	X	X	Yes	
<b>Recommended Spare Parts</b>								
2.1	12-1360	Overload with Manual Reset - 97°C (206°F) <i>Recommend stocking 2 each per every 10 units ordered</i>	HT-3012		X	X	Yes	
2.2	12-1303	Hot Tank Thermostat - (87°C - 189°F) <i>Recommend stocking 2 each per every 10 units ordered</i>	HT-3013A		X	X	Yes	
2.3	12-6900	Hot Tank Supplemental Steel Enclosure <i>Recommend stocking 2 each per every 10 units ordered</i>	ST-8291		X	X	Yes	
4	12-3140	Drip Tray Grill <i>Recommend stocking 2 each per every 10 units ordered</i>	PL-1242-CN	X	X	X	Yes	
5	10-2500	Black O-Ring for Quartz Sleeve <i>Recommend stocking 2 each per every 10 units ordered</i>	CT-2006	X	X	X	Yes	

6	10-1400	Quartz Sleeve for 8W Lamp <i>Recommend stocking 2 each per every 10 units ordered</i>	CT-2002	X	X	X	Yes	
7	12-3130	Drip Tray Body with <b>Aramark</b> Logo <i>Recommend stocking 2 each per every 10 units ordered</i>	PL-1237-CN	X	X	X	Yes	
8	12-1500	Solenoid Valve DC24V 1000mm <i>Recommend stocking 2 each per every 10 units ordered</i>	PU-4016	X	X	X	Yes	
9	10-3048	Blue Faucet Nipple, with Stainless Steel Gauze <i>Recommend stocking 2 each per every 10 units ordered</i>	PL-1013	X	X	X	Yes	
9.1	10-2600	White Silicon Faucet O-Ring <i>Recommend stocking 2 each per every 10 units ordered</i>	CT-2007	X	X	X	Yes	
10	12-8057	Button Label <i>Hot and Cold</i> <i>Recommend stocking 2 each per every 10 units ordered</i>	LP-7084		X	X	Yes	
	12-8610	Button Label <i>Cold Only</i> <i>Recommend stocking 2 each per every 10 units ordered</i>	LP-7085	X			Yes	
11	12-3135	Silicon Button Key Mat <i>Hot and Cold</i> <i>Recommend stocking 2 each per every 10 units ordered</i>	PL-1239-CN		X	X	Yes	
	12-8600	Silicon Button Key Mat <i>Cold only</i> <i>Recommend stocking 2 each per every 10 units ordered</i>	PL-1100	X			Yes	
Not Shown	01-2076	ScaleKleen <i>Recommend stocking 2 each per every 10 units ordered</i>	NA	X	X	X	Yes	
<b>Remaining Parts</b>								
12	10-2700	Faucet Assembly – Hot and Cold	PL-1011	X	X	X	Yes	



	NA	Faucet <i>Cold Only</i>	PL-1012	X	X	X	Yes	
13	12-3120	Front Panel for Drip Tray Insert	PL-1201-CN	X	X	X	Yes	
14	12-3160	PCB Cover	PL-1298	X	X	X	Yes	
15	12-8103	PCB for Hot and Cold	EN-6085		X	X	Yes	
	12-8615	PCB for Cold Water	EN-6086	X			Yes	
15.1	10-3017	PCB Stand-off Pin	EN-6059	X	X	X	Yes	
16	12-3125	Front Upper Panel	PL-1236- L00-SI	X	X	X	Yes	
17	12-3220	Silver Side Panel	ST-8192-CN	X	X	X	Yes	
18	12-8058	Side Panel Plastic Handle	PL-1123	X	X	X	Yes	
19	Purchase from John Guest	JG ¼" Stopper PI0808S	PU-4086	X	X	X	No	
20	10-3067	Bulkhead Union ¼" x ¼" John Guest P/N PI1208S	PU-4028-A	X	X	X	Yes	
21	12-3205	Front Lower Panel	PL-1202-CN	X	X	X	Yes	



22	12-3200	Front Lower Insert Panel	PL-1238-CN	X	X	X	Yes	
23	Purchase from John Guest	1/4" Union Elbow John Guest P/N P10308S	PU-4008-A	X	X	X	No	
24	Purchase from John Guest	3/8" Union Tee John Guest P/N P10208S <i>Hot and Cold</i>	PU-4011-A	X	X	X	Yes	
25	CU-0001	Solenoid Cushion	CU-0001	X	X	X	Yes	
26	NA	Filter Bracket	ST-8168-CN	X	X	X	No	
27	NA	Rubber O-Ring for Filter Bracket	PL-1208CN	X	X	X	No	





**Verify compressor in machine before ordering parts as the Compressor P/N CO-0020-L00-00 and 10-2200 (CO-0001A) and related parts are not interchangeable.**

#### CO-0020-L00-00 Compressor

28A.1	CO-0020-L00-00	LG Compressor 120V R134A CSB035LJCM	CO-0020-L00-00	X	X	X	Yes	
28A.2	CO-0019-L00-00	Compressor Capacitor	CO-0019-L00-00	X	X	X	Yes	
28A.3	ST-0216-L00-00	Capacitor Bracket	ST-0216-L00-00	X	X	X	Yes	
28A.4	CO-0017-L00-00	PTC Relay	CO-0017-L00-00	X	X	X	Yes	
28A.5	CO-0018-L00-00	Overload Protector	CO-0018-L00-00	X	X	X	Yes	

CO-9001-A / 10-2200 Compressor								
28B.1	10-2200	Compressor (R134a 1/8HP) 120V/60Hz	CO-9001-A	X	X	X	Yes	
28B.2	10-3003	Compressor Starter Relay	CO-9016	X	X	X	Yes	
28B.3	10-5018	Compressor Overload	CO-9015	X	X	X	Yes	
29	12-3180	Leak Containment Tray Clip (Sensor 0.5mm)	ST-8207-CN	X	X	X	Yes	
30	NA	Leak Tray	PL-1294-A	X	X	X	No	
31	12-8004	Bottom Tray	ST-8137	X	X	X	Yes	
32	10-3083	Unit Control Rubber Feet	ST-8167CN	X	X	X	Yes	
33	NA	Back Panel Silver	ST-8247	X	X	X	No	
34	12-1101	Cold Tank Thermostat	CT-2016	X	X	X	Yes	
34.1	PL-0326	Cold Thermostat Cover Label	PL-0326-L00-00	X	X	X	Yes	
35	10-4013	Power Line Noise Filter, ElectroMagnetic Interference filter (EMI)	EL-5016	X	X	X	Yes	
36	10-3014	Fuse Holder and Fuse 120V / 15A with One Wire	EL-5053	X	X	X	Yes	

36.1	10-3013	Fuse 120V / 15A	EL-5010	X	X	X	Yes	
37	10-3008	Red Compressor and Heater Switch	EL-5004	X	X	X	Yes	
38	12-8003	Upper Shelf	ST-8136-R2	X	X	X	Yes	
39	10-3010	UV Lamp Ballast 110V/60Hz	EL-5006-A CN	X	X	X	Yes	
40	12-3117	Power Transformer UV 120V / 60Hz	EL-5003-A	X	X	X	Yes	
41	12-1210	UV Lamp Retaining Threaded Nut	PL-1128	X	X	X	Yes	
42	12-5245	PCB Fixing Bracket	ST-8165-CN	X	X	X	Yes	
43	12-8510	3 Minutes UV Timer PCB Hot and Cold	AK-0008-A		X	X	Yes	
	12-8520	3 Minutes UV Timer PCB Cold Only	AK-0008-C	X			Yes	
44	NA	Cold Tank 4 Liter Assembly with UV Holder	CT-2050	X	X	X	No	
45	12-9000	<u>Stone</u> Top Cover	AK-0035			X	Yes	
	12-3255	<u>Plastic</u> Top Cover	PL-1300	X	X		Yes	
46	12-8102	Wire Condenser	CO-9027	X	X	X	Special Order	

47	NA	JG LLD PE Tube - Blue O.D.1/4" John Guest P/N PE-08-BI-1000F-B	PU-4031-A	X	X	X	Purchase from John Guest	
48	10-3062	JG LLDPE Tube - Blue 8mm John Guest P/N PE-0806-100M-B	PU-4014-A	X	X	X	Yes	
49	NA	5/16" x 1/4" Reducing Elbow John Guest P/N PI211008S	PU-4007-A	X	X	X	Purchase from John Guest	
Not Shown	10-7040	Silicon Tube 5/16" for Hot Water	PU-4064		X	X	Yes	
Not Shown	10-3007	Power Cord 120V – 1840 mm	EL-5001-B	X	X	X	Yes	

## ASSEMBLING SINGLE RC-1 REFRESH CENTER

Sliding Top and the Filter needs to be installed prior to connecting the unit to water.

### Installing Sliding Top

The Sliding Top installs onto the rails on the top of the unit much like a draw would install into a desk or piece of furniture.

1. Align Rails on the machine into the grooves on the underside of the top. Slide the Top toward the rear of the unit until you hear it “click” into place.

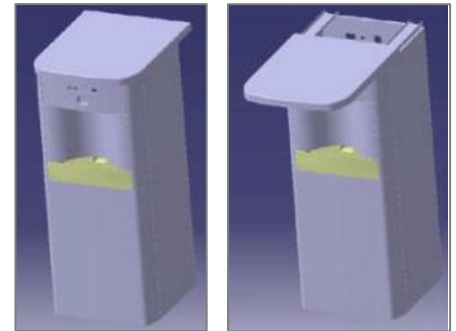

2. Once the Top is installed and slid all the way to the rear of the machine, engage the lock on the back to secure the top into place.



### Removing Sliding Top

1. Unlock the Top, insert screwdriver as shown, to spring the lock open.



2. Reverse steps for installing the Top, as shown.



## Installing the Filter Head

A Filter Head will need to be installed in the Refresh Center. The Filter Head was supplied to you via a separate package from **Waterlogic**. To install the Filter Head, you will need to remove the Lower Front Panel that is located under the Drip Tray of the machine. For UL certification purposes, this lower door is secured via 2 screws located on the underside of the unit. UL requires all areas of access to wiring and high voltage components to be protected such that access requires the use of a tool. When you install the Refresh Center in a customer location, be sure that these screws are re-installed to ensure no one inadvertently gains access to the internals (compressor) and associated wiring.

1. To remove the Lower Panel, lean the unit back and remove the two Philips-head screws on the bottom. Once the screws are removed, bring the unit back to the upright position, and press in one of the detents in the bottom of the panel and remove.





2. Once the Lower Front Door is removed, the Filter Head needs to be installed on the filter plate, as shown in the figure below. Make sure you connect the Tubing to the Fittings in the Filter Head prior to actually mounting the head on the screws provided on the Filter Plate. This will minimize the chances for kinking the water tubes.

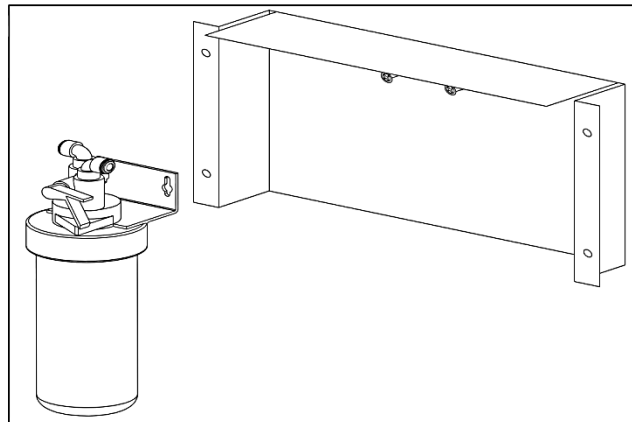

**Once the Filter Head is installed and piped, install a PRE-RINSED filter into the head, connect a water supply, power the unit, and check for leaks. DO NOT turn on the Red Power switch on the back of the unit until the tanks are filled with water.**

3. To fill the Hot and Cold Tanks, depress the Water Dispensing Button until water flows from the Faucet (requires about 60 seconds to fill the cold tank). Once the Cold Tank is filled, briefly depress the Hot Water Selection Button, notice that the center LED changes from green to red, then press the Dispensing Button until water flows from the Faucet indicating that the Hot Tank is full.

*Note: When the Hot Water Selection button is pressed and the center LED lights red, you have 2 seconds to begin dispensing water. If water is not dispensed within 2 seconds, the center LED will revert to green (default dispense) and cold water automatically will be selected.*

4. Once both the Hot and Cold Tanks are filled, turn the Red Power Switch on (I=ON) the back panel of the unit.



## **ASSEMBLING DOUBLE RC-2 REFRESH CENTER**

Once the cabinet is bolted to the cooler, the Sliding Top and the Filter needs to be installed prior to connecting the unit to water.

### **Mounting the Cabinet**

1. Inside the Cabinet, locate the Hardware bag and Keys.
2. To remove the Lower Panel, lean the unit back and remove the two Philips-heads screws on the bottom. Once the screws are removed, bring the unit back to the upright position, and press in one of the detents in the bottom of the Panel and remove.



- Using the hardware supplied, bolt the cabinet to the cooler. Six total bolts, washers and nuts are needed for this step, however, mounting of the back-middle bolt and nut can be omitted due to access, if desired.

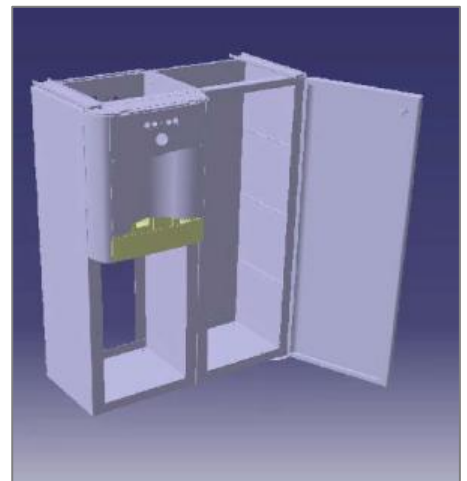
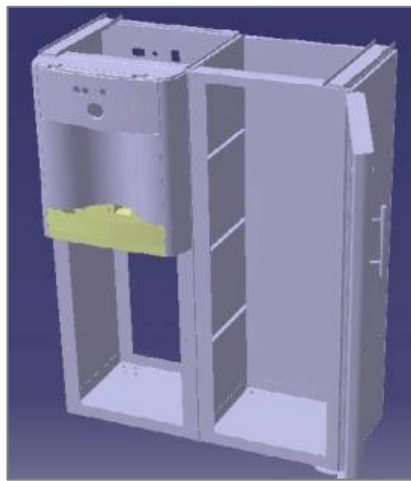
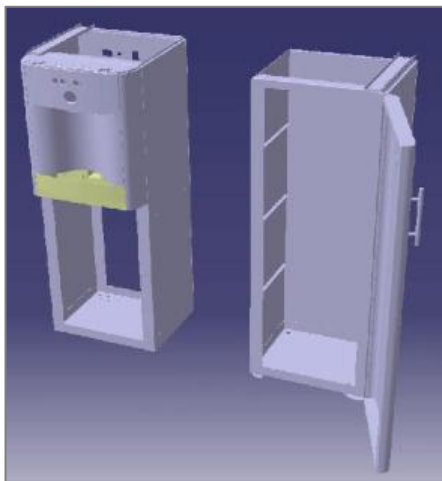
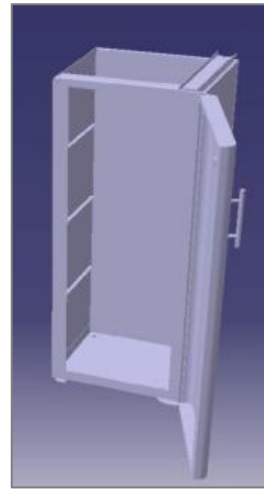
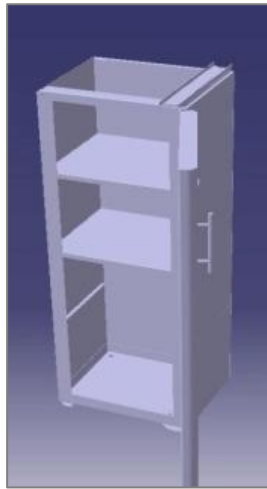

## Installing the Sliding Top

The sliding top installs onto the rails on the top of the unit much like a draw would install into a desk or piece of furniture.

1. Align rails on the machine into the grooves on the underside of the top. Slide the top toward the rear of the unit until you hear it “click” into place.

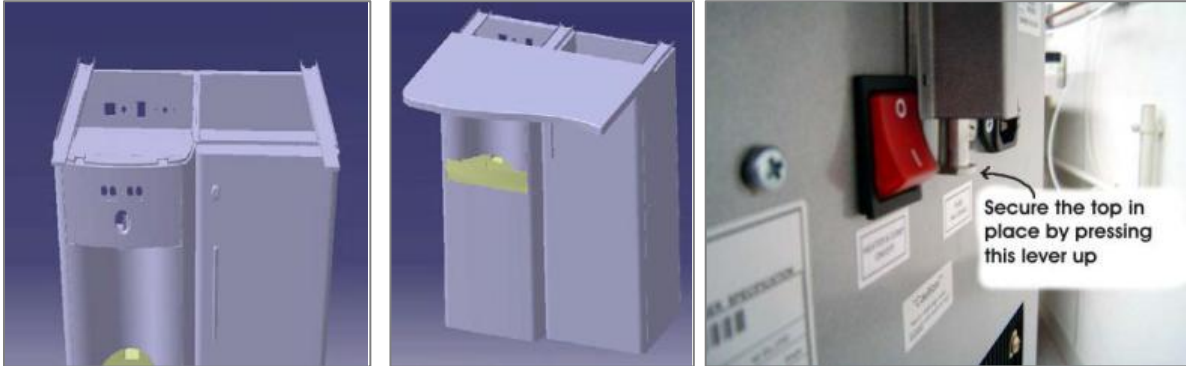

2. Once the top is installed and slid all of the way to the rear of the machine, engage the lock on the back to secure the top in place.

## Removing Sliding Top

1. To unlock the top, insert screwdriver as shown to spring the lock open.

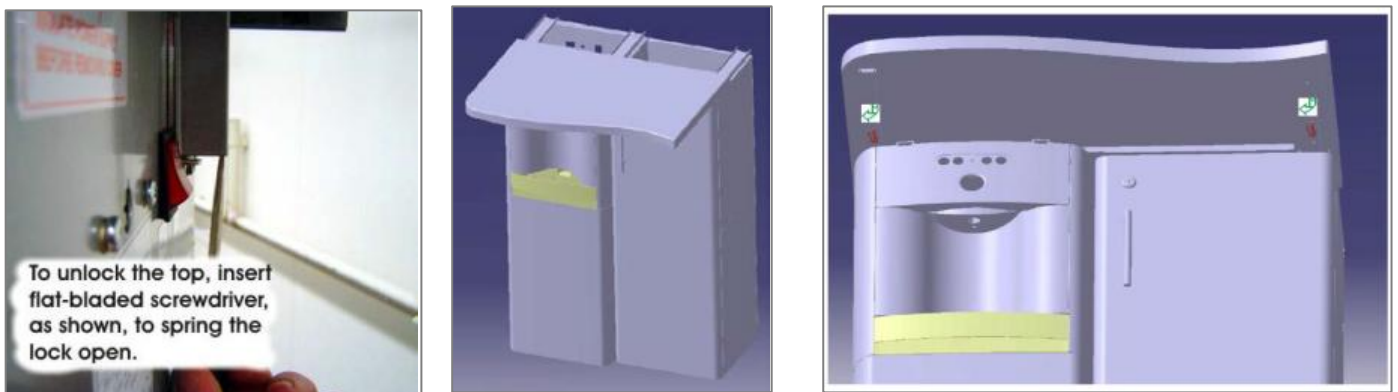

## Installing the Filter Head

A Filter Head will need to be installed in the Refresh Center. The Filter Head was supplied to you via a separate package from **Waterlogic**. To install the Filter Head, remove the Lower Front Panel that is located under the Drip Tray of the **Aramark Refresh Center**. For UL certification purposes, this Lower Door is secured with 2 screws located on the underside of the **Aramark Refresh Center**. UL requires all areas of access to wiring and high voltage components to be protected such that access requires the use of a tool. When you install the **Aramark Refresh Center** in a customer location, be sure that these screws are re-installed to ensure no one inadvertently gains access to the internals (compressor) and associated wiring.

1. To remove the Lower Panel, lean the **Aramark Refresh Centers** unit back and remove the two Philips-head screws on the bottom. Once the screws are removed, bring the unit back to the upright position, and press in one of the detents in the bottom of the panel and remove. Note that the Lower Panel on the **Aramark Refresh Center** unlocks.

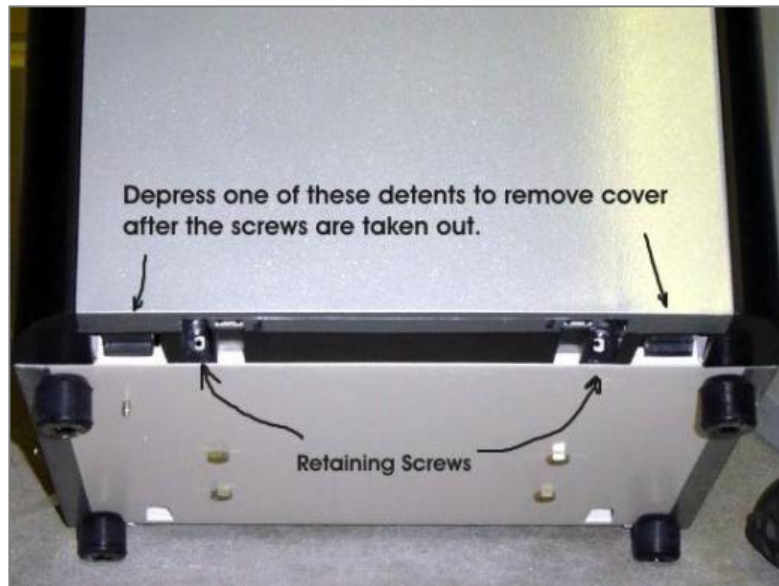

2. Once the Lower Front door is removed, the Filter Head needs to be installed on the filter support plate, as shown in the figure below. Connect the tubing to the fittings in the head prior to actually mounting the head on the screws provided on the filter plate. This will minimize the chances for kinking the water tubes.

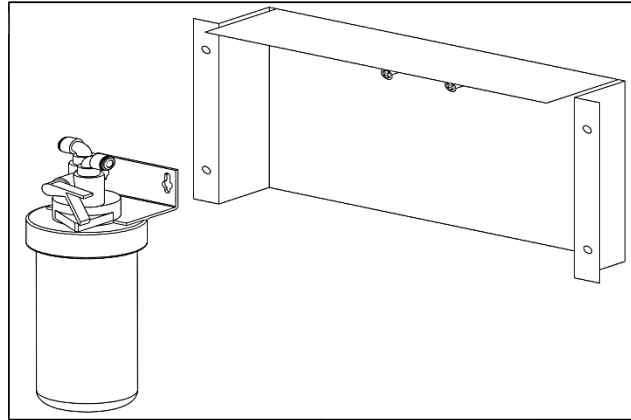

Once the Filter Head is installed and piped, install a PRE-RINSED Filter into the Filter Head, connect to a water supply, power the *Aramark Countertop or Refresh Center*. Check for Leaks. Keep the Red Power Switch OFF (O=OFF) on the back of the unit until the tanks are filled with water.



3. To fill the Hot and Cold Tanks, Depress the Dispensing Button until water flows from the faucet (requires about 60 seconds to fill the Cold Tank). Once the Cold Tank is filled, momentarily depress the Hot Selection Button, notice the center LED changes from green to red, then press the Dispensing Button until water flows from the Faucet indicating the hot tank is full.

*Note: When the Hot Selection Button is pressed and the center LED lights red, you have 2 seconds to begin dispensing water. If water is not dispensed within 2 seconds, the center LED will revert to green (default dispense) and cold water automatically will be selected.*

4. Once the Hot and Cold Tanks are filled, turn on the Red Power Switch I=ON located on the Back Panel of the *Aramark Countertop or Refresh Center*.





## ARAMARK CENTERS COUNTER TOP WATER FLOW DIAGRAM

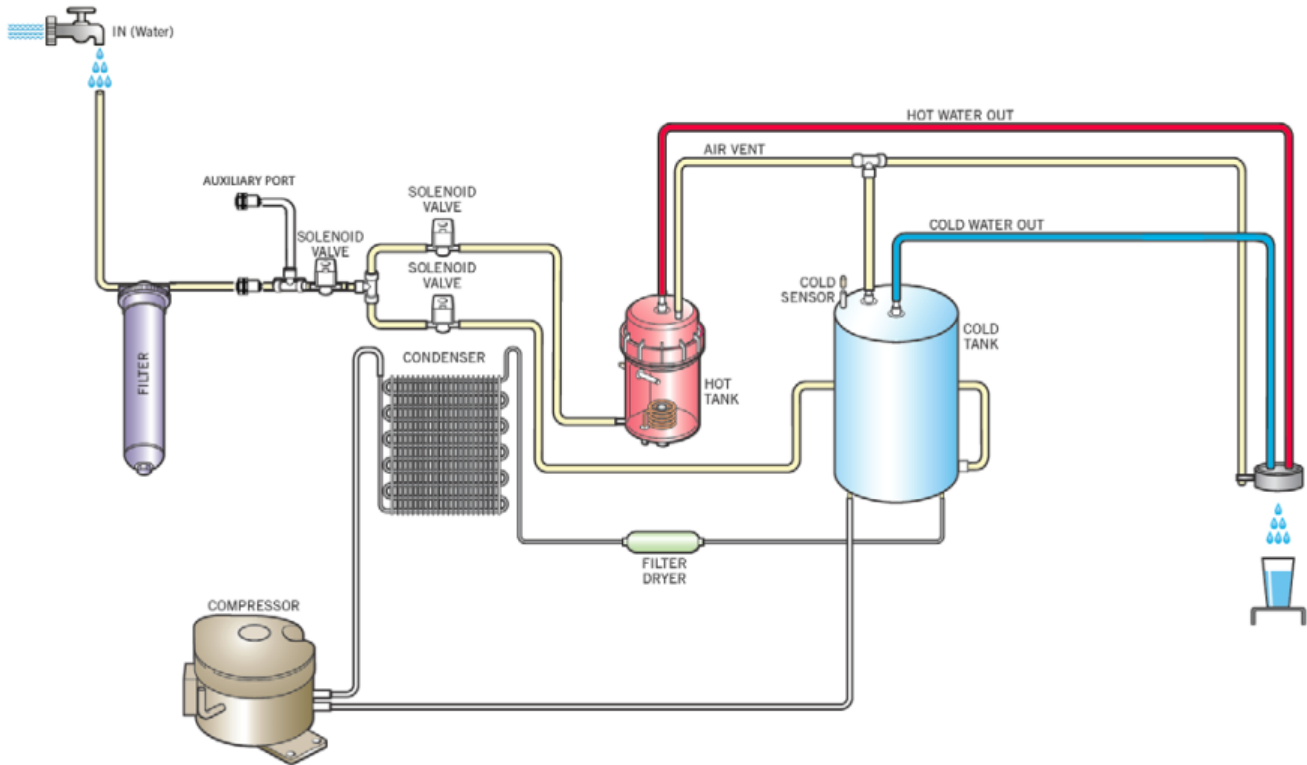

## ARAMARK REFRESH CENTERS WATER FLOW DIAGRAM

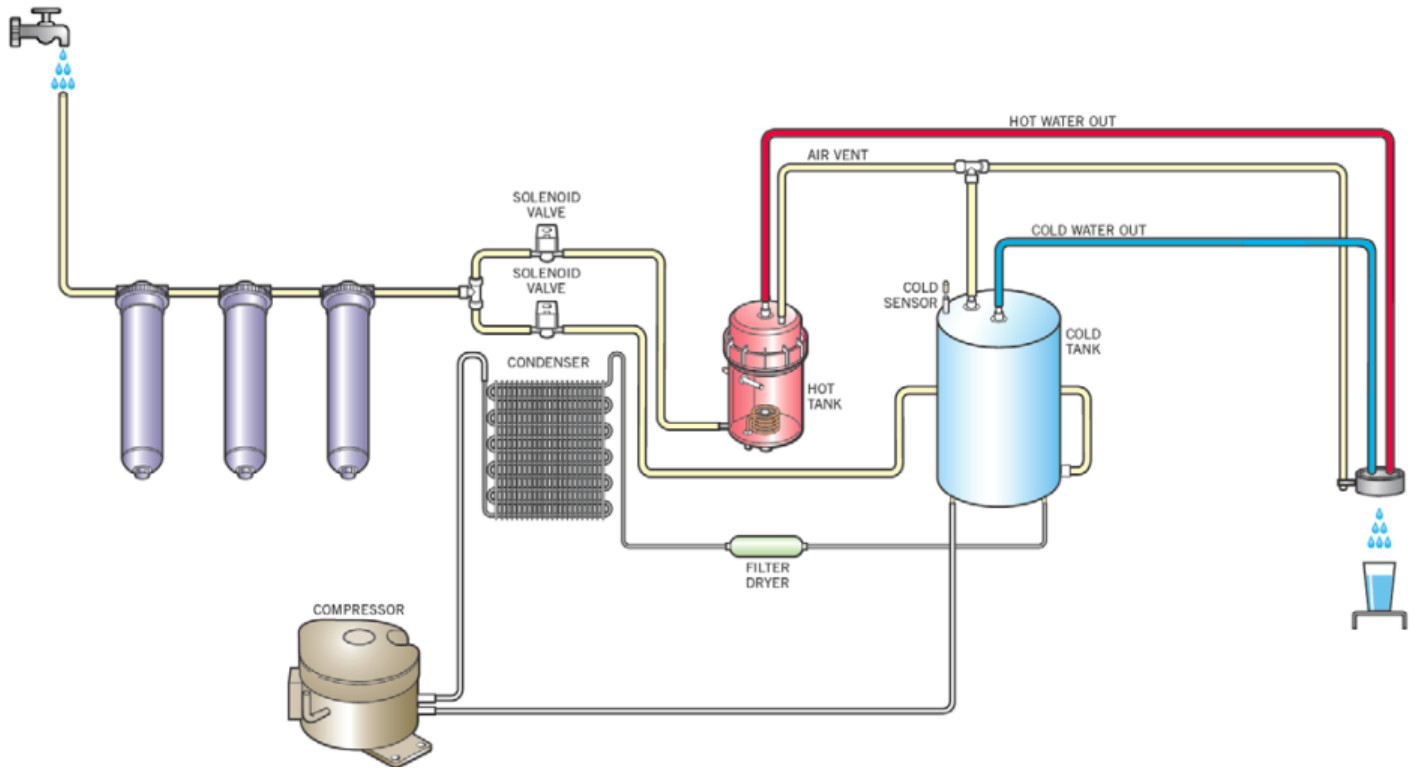

## ADJUSTING COLD SET POINT

Cold Water Temperature – Factory Set Point is 41°F (5°C) and can be adjusted to 34°F - 54°F (1.1°C to 12.2°C)

The cold set point can be adjusted by accessing the cold thermostat adjustment screw under the decal at the rear of the unit.



Remove the red portion of the Cold Tank Temperature label to access the adjustment screw.

The factory set point is ~41°F and is indicated by the dot on sheet metal.



Turning the adjustment screw clockwise to lower the set point temperature.

Do not adjust past the “Max Cold” position at 3:00 position to avoid freezing the cold tank.



Turning the adjustment screw counter-clockwise to raise the set point temperature.



## **PRE-INSTALLATION PROCEDURES**



### **DANGER! ELECTRICAL SHOCK HAZARD.**

*Only qualified personnel who have read and understand this entire manual should attempt to install, or service this **Aramark Countertop or Refresh Center**. Failure to do so could result in death or serious injury. DO NOT plug into an electrical supply until specifically instructed.*



### **WARNING! ALWAYS SANITIZE BEFORE USE.**

*Sanitize before use to eliminate any potential microbiological contaminants.*



### **CAUTION! DRIP TRAY DRAIN.**

*If you intend to provide a drip tray drain for your customer, be aware that you will be called multiple times per month to service and unclog the tubing leading away from the drip tray to drain. Users will clog the drain with paper clips, erasers, napkins, tea bags, gum, and various other intended items. Waterlogic recommends you establish a minimum of weekly visits to the machine for cleaning of the drip tray drain.*

### **Materials Needed:**

- Personal Protective Equipment. Rubber or Nitrile Safety Gloves and Protective Eyewear
- Phillips Screwdriver
- Temperature Gage
- Water Pitcher or Container to collect water from the faucet
- 5-gallon container or drain basin
- Sanitizer - Household Bleach (5.25% Sodium Hypochlorite) or Citric Acid Based Cleaner
- ¼" Plastic Tubing, at least 4 feet in length, and assorted ¼" quick connect fittings
- TDS Meter and Test Strips for measuring chlorine - Optional

1. Unpack the **Aramark Countertop or Refresh Center** and check exterior for damage.

### **Flush Filters**



### **CAUTION! FILTER FLUSH REQUIRED.**

***Aramark Countertop and Refresh Centers** are not supplied with filters. Filters should be configured to optimize your system. Filters need to be configured and specified to do the job given the local water conditions, usage, maintenance schedule, and placement restrictions.*

*In order for our filters to perform as represented and to provide the best quality water possible, it is essential that filters be replaced periodically. The frequency of filter changes depends upon your water quality and your water usage. For example, if there is a lot of sediment and/or particles in your water, then you will have to change your filters more frequently than a location with little to no sediment. Be sure to replace your filters whenever you notice a decline in the performance, whether it is a drop in flow rate and/or pressure or an unusual taste in the water.*

2. Flush thoroughly per filter manufacturers' recommendation with fresh water to drain.

3. Once flushed, install the filters. Following the flow direction on the filter.

**NOTE:** Filters should not be flushed prior to 24 hours before installation to limit Microbial Growth.

### Sanitizing

Sanitize using a Household Bleach (5.25% Sodium Hypochlorite solution) or other approved cleaner throughout the cold and sparkling water circuits. Follow all instructions on the sanitizer and flush with fresh water through the faucet until odor and taste is acceptable.

**⚠ WARNING! USE PROPER PERSONAL PROTECTIVE EQUIPMENT**

*Always ensure proper ventilation and use proper personal protective equipment such as gloves and eye protection when using chemicals. Refer to Material Safety Data Sheet for specific requirements of each chemical product. Take all necessary precautions to prevent sanitizer from contacting eyes, clothing, and any other surfaces in could damage (carpets).*

4. Disconnect the UV Lamp wiring harness and carefully remove the UV Lamp from the quartz sleeve.

**⚠ CAUTION! UV SYSTEM IS FRAGILE.** *Never handle the UV System with bare hands. UV Lamp and Quartz Sleeve must be free of oils and contaminants to ensure proper operation.*

5. Unscrew Cold Tank/Quartz Sleeve retaining cap and remove the Quartz Sleeve. This will require Top Cover to be removed to access properly and facilitate removal.



Retaining Cap



6. Mix ½ gallon of sanitizer per directions or use Bleach Solution (1 teaspoon = 1/6 oz. = 5 ml = ½ cap full) of household bleach (Sodium Hypochlorite 5 - 10% Concentration) with 1/2 gallon of water. Always ensure sanitizer is compatible with stainless steel and acetyl plastic.
7. Pour sanitizer solution through UV Port into Cold Tank with a funnel or spout. You may add concentrated sanitizer (½ cap bleach) directly into empty cold tank instead of premixing.
8. Inspect and clean Quartz Sleeve and O-ring.
9. Reinstall the Quartz Sleeve and Quartz Sleeve Retaining Nut. Tighten firmly to ensure proper seal. Over-tightening can cause damage.

**⚠ CAUTION! DO NOT INSTALL THE UV LAMP AT THIS TIME**

*The UV will interact with the sanitizer and could potentially cause taste.*



10. Connect 40-60 psi regulated, potable water supply to the water inlet bulkhead fitting located on the back of the **Aramark Countertop or Refresh Center**. Turn on water supply and check for leaks.

**⚠ DANGER! ELECTRICAL SHOCK HAZARD.**

*Do not plug in unit unless qualified. Only qualified personnel who have read and understand this entire manual should attempt to install or service this unit.*

11. Connect **Aramark Countertop or Refresh Center** to power.

**⚠ CAUTION! NEVER TURN ON HEATER BEFORE FILLING HOT TANK.**

*Red Heater and Compressor Power Switch must be in the O=OFF position while the hot tank is empty. Damage could occur within one minute and the overload (high limit) will require manual reset if heater is turned on with an empty hot tank.*



### Fill the Cold Circuit with Sanitizer

12. Depress the main dispensing button on the front control panel until cold water/sanitizing solution comes out the faucet. **NOTE:** Container and drain basin will be required to catch the water from the faucet.

**⚠ WARNING!** *Use Personal Protective Equipment. Gloves and Eye Protection Required. The first 2 or 3 gallons of water will contain concentrated sanitizer. Use extreme care!*

### Flushing the Sanitizer from the Machine

13. Place a pitcher, catch basin, or other container under the faucet of the **Aramark Countertop or Refresh Center**.
14. Flush the Cold Tank. Run several gallons of water through the faucet by dispensing cold water to dilute and remove the sanitizer from the cold circuit. You can use chlorine test strips to evaluate the water.
15. Once the sanitizer odor/taste has been flushed out of the cold side of the machine the sanitization process for the Cold Circuit is complete.

### Fill the Hot Tank

16. Press the Hot Water Select Button, followed by the main dispensing button to fill the hot tank. Water will dispense from the faucet once the hot tank is full. Flush until water is clear.

**⚠ WARNING! HOT CIRCUIT IS NOT SANITIZED.**

*Water in the hot circuit is not sanitary until the temperature exceeds 77°C (171°F) for at least 5 minutes.*

### UV System Functional Test

**⚠ WARNING! ULTRAVIOLET RADIATION.** *Protect your skin and eyes against ultraviolet rays. Never look directly at an operating UV light. Disconnect wiring before removing.*

17. Reinstall the UV Lamp and connect the wiring.
18. Dim or shield the overhead lights and peer into the machine, on top of the Cold Tank, at the UV connector and retaining cap. The blue glow indicates that the lamp is lit.

### Compressor Test

19. Switch Red Compressor / Heater to *I=ON position*. Always ensure tanks are full of water before turning on the heater or the overload (high limit) will open and require manual reset. If the wire condenser at back of the **Aramark Countertop or Refresh Center** is warm, the refrigeration system is working.



20. Once the machine reaches its target temperature, the compressor will shut off. Draw a glass of cold water and verify it has been chilled to proper temperature.

### Heater Test

21. Always ensure tanks are full of water before turning on the heater or the overload (high limit) will open and require manual reset. It will take the heater approximately 10 minutes to heat the water from ambient 24°C (75°F) to the factory set point of 85°C (185°F). Dispense a cup of hot water to ensure the temperature/odor/taste is acceptable.

**⚠ WARNING! HOT WATER.** *Unit produces Hot Water up to 87°C (188°F). Water above 52°C (125°F) can cause severe burns or scalding. Hot water should be dispensed carefully into insulated container to avoid injury.*

## COUNTER TOP DRAINING INSTRUCTIONS

### Draining Notes

Drain the *Aramark Countertop* for transportation.

- ⚠ WARNING!** **STORE UNIT EMPTY. ALWAYS SANITIZE BEFORE REUSE.**  
*The unit must be completely drained and sealed before storing to avoid stagnation and reduce microbial growth).*

Prior to draining the hot tank, turn off the Red Heater and Compressor Power Switch (*O=OFF*), and dispense 2 liters of hot water from the machine. As hot water is dispensed from the faucet of the unit, colder water will be introduced into the Hot Tank. Since the Red Heater and Compressor Power Switch is turned off, the heater will not energize and heat the incoming tap water. Following this precaution prevents exposing personnel and equipment (drains, catch basin, etc.) to scalding hot water.



### Disable Cold and Hot Tanks

1. Turn off the Red Heater and Compressor Power Switch (*O=OFF*) to disable the heater and compressor.
2. Dispense 2 liters (1/2 Gallon) of water through the hot tank to cool the water temperature in the hot tank and avoid burns.



- ⚠ WARNING!** **HOT WATER.** *The Aramark Countertop produces Hot Water up to 87°C (188°F). Water above 52°C (125°F) can cause severe burns or scalding. Hot water should be dispensed carefully into insulated container to avoid injury.*

### Disable Cold and Hot Tanks

3. Turn off the Red Heater and Compressor Power Switch to disable the heater and compressor.
4. Dispense 2 liters of water through the Hot Tank to cool the water temperature in the Hot Tank and avoid burns.



- ⚠ WARNING!** **VERY HOT WATER CAN BURN OR SCALD.**  
*Hot water should be dispensed carefully into insulated container to avoid injury.*

### Turn off Water Supply and Bleed Water Pressure

5. Isolate the unit from feed water by turning off the supply.
6. Dispense cold still water to relieve any pressure built up in the system.

7. Remove the water supply line from the Inlet Line Bulkhead fitting at back of machine.
8. Install dust cap or plug into water supply line bulkhead fitting.

### Drain the Cold Water Tank and Circuit

9. Remove Top Cover.
10. Remove Front Panel. Remove 2 Phillip screws securing Front Panel.
11. Disconnect Tubing from Inlet Elbows on both Solenoids and allow water to drain.

Unseat Faucet Assembly from Panel. Unclip wires from PCB.

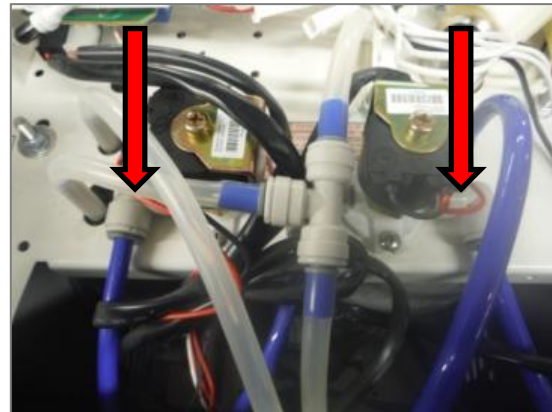
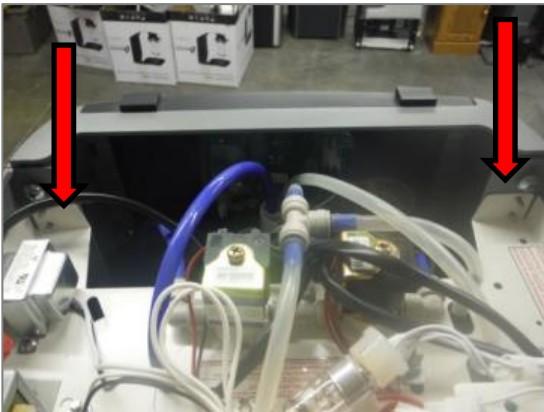

12. Reconnect Tubing into Inlet Elbows.



13. Dry inside of the *Aramark Countertop Water Treatment System*.
14. Replace Front Panel.

## REFRESH CENTER DRAINING INSTRUCTIONS

### Draining Notes

Drain the *Aramark Refresh Center* for transportation.

**⚠ WARNING!** *STORE UNIT EMPTY. ALWAYS SANITIZE BEFORE REUSE.*

*The unit must be completely drained and sealed before storing to avoid stagnation and reduce microbial growth).*

Prior to draining the Hot Tank, turn off *O=OFF* the Red Heater and Compressor Power Switch, and dispense 2 liters of hot water from the machine. As hot water is dispensed from the Faucet of the unit, colder water will be introduced into the Hot Tank. Since the Red Power Switch is turned off, the heater will not energize and heat the incoming tap water. Following this precaution prevents exposing personnel and equipment (drains, catch basin, etc.) to scalding hot water.



### Disable Cold and Hot Tanks

1. Turn off *O=OFF* the Red Heater and Compressor Power Switch to disable the heater and Compressor.
2. Dispense 2 liters of water through the Hot Tank to cool the water temperature in the Hot Tank and avoid burns.



**⚠ WARNING!** *HOT WATER.* *The Aramark Refresh Center Water Treatment System produces Hot Water up to 87°C (188°F). Water above 52°C (125°F) can cause severe burns or scalding. Hot water should be dispensed carefully into insulated container to avoid injury.*

### Turn off Water Supply and Bleed Water Pressure

3. Isolate the *Aramark Refresh Center* from feed water by turning off the supply.
4. Dispense cold still water to relieve any pressure built up in the system.
5. Remove the water supply line from the Inlet Line Bulkhead Fitting at back of machine.
6. Install dust cap or plug into water supply Inlet Line Bulkhead Fitting.

### Drain the Cold-Water Tank and Circuit

7. Remove Lower Front Panel to access tank feed lines.

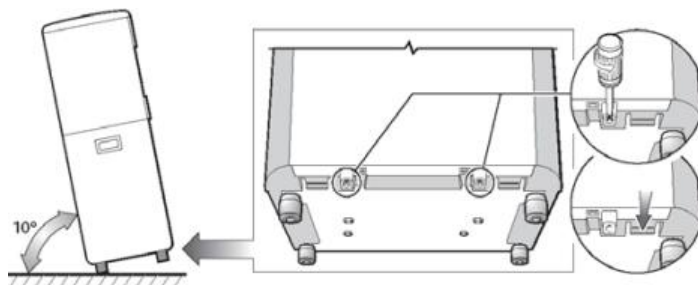

8. Disconnect tank line feed lines from Hot and Cold inlet solenoids to drain into basin or catch.

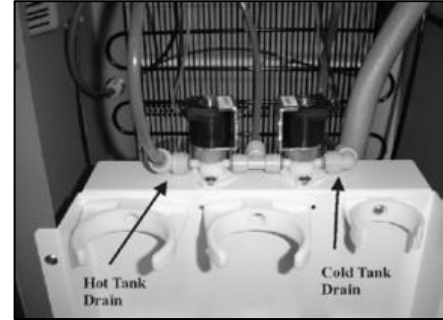

9. Reconnect Tubing into Inlet Elbows once drained.
10. Dry inside of **Aramark Refresh Center** as necessary.
11. Replace Lower Front Panel.



## INSTALLATION PROCEDURES

### Safety and Installation Guidelines

Ensure all Local, State, and Federal Laws and Codes including health and safety guidelines are met when installing **Waterlogic** Equipment. Only qualified service technicians should attempt installation and service of **Waterlogic** Equipment.

- ⚠ WARNING! ELECTRICAL SHOCK HAZARD.** Always unplug (isolate from power supply) to prevent electrical shock except where electrical tests are specified.
- ⚠ WARNING! IMPROPER SUPPLY OR CONNECTION CAN RESULT IS RISK OF SHOCK.** Connect to a 15 amp, 120V 60Hz properly grounded outlet (GFI is recommended). Ensure polarity is correct and always use a 3-prong outlet. Consult a qualified electrician if you have any questions.
- ⚠ WARNING! USE ONLY Waterlogic SUPPLIED POWER CORD.** Locate system within 5 feet of power supply. Never use an extension cord or adapter. Do not use a damaged power cord or plug. Keep power cord out of heavy traffic areas and away from heat sources. Do not, under any circumstances, remove ground prong or alter the power cord. Never pull the power plug from the outlet with a wet hand or allow the plug to get wet. Failure to use the supplied power cord will void UL Certification and Warranty.
- ⚠ CAUTION! INDOOR USE ONLY.** Never expose to direct sunlight, heat sources, or ambient air temperature above 38°C (100°F) or below 2°C (35°F). Install indoors and keep unit away from excessive humidity. Never expose to freezing temperatures. Ensure there is adequate clearance around the unit to allow refrigeration system condenser to dissipate heat. Warmer environments require more clearance around the unit. Minimum clearance around all surfaces of the machine is 2-inches. Installs where the ambient temperature exceeds 80°F, require a minimum of 4-inches clearance for proper heat dissipation and efficient operation.
- ⚠ CAUTION! USE A WATER PRESSURE REGULATOR.** **Waterlogic** will not be responsible for injury or damage caused by excessive water pressure. Operating pressure must be 40 psi to 60 psi. Be aware any of potential pressure surges caused by building/municipal pumping stations.
- ⚠ CAUTION! USE UV STABILIZED SUPPLY LINES.** Feed the unit with a potable ambient or cold-water supply only. Feed water over 100° F (37°C) can damage the treatment components. Water block devices and external leak detectors are strongly recommended. Locate the unit as close to the water supply and the electrical connections as possible.
- ⚠ WARNING! STORE AND TRANSPORT UNIT EMPTY. ALWAYS SANITIZE BEFORE USE.** The unit must be completely drained and sealed before storing to avoid stagnation and reduce microbiological contamination (potential bacterial growth). Sanitize before use to eliminate any potential microbiological contaminates

Pre-installation and sanitization procedures as prescribed in this manual must be performed before installing the **Aramark Countertop or Refresh Center**.

Always install indoors and place the **Aramark Countertop or Refresh Center** on a firm, flat and stable surface.

1. Attach the water supply line to the 1/4" feed water inlet bulkhead fitting on the back of the **Aramark Countertop or Refresh Center** and requires the use of a water pressure regulator. Water feed pressure must be between 40-60 psi. Turn on the water supply and check for leaks.

2. Check to ensure that the Red Heater and Compressor Power Switch is the *O=OFF* position.



**NOTE:** Switches have internal LED that illuminates when placed in *I=ON* position.

3. Connect the power cord to the back of the **Aramark Countertop or Refresh Center** to a 120 Volt supply.
4. Fill the Cold Tank. Hold a container under the dispensing faucet, press and hold the main dispensing button until a continuous flow of water is obtained. Once a continuous flow is obtained, release the dispensing button. Cold tank is now full.
5. Fill the Hot Tank. Hold a container under the dispensing faucet. Press the Hot Select Button followed by the main dispensing button until a continuous flow of water is obtained. Once a continuous flow is obtained, release the main dispensing button. Hot tank is now full.

**⚠ CAUTION! NEVER TURN ON HEATER BEFORE FILLING HOT TANK.**

*Red Heater and Compressor Power Switch must be in the O=OFF position while the Hot Tank is empty. Damage could occur within one minute and the overload (high limit) will require manual reset if heater is turned on with an empty Hot Tank.*



6. Verify that the UV Lamp operates as expected.

**⚠ WARNING! ULTRAVIOLET RADIATION.** *Protect your skin and eyes against ultraviolet rays. Never look directly at an operating UV light. Always disconnect before removal.*

7. Move the **Aramark Countertop or Refresh Center** into its final operating position. Be sure that a minimum of 2" clearance is maintained around both sides and the back of the **Aramark Countertop or Refresh Center**.
8. This is important to allow proper airflow and heat exchange of refrigeration system.
9. Level **Aramark Countertop or Refresh Center** using the adjustable feet to level if necessary. Never install on incline.

10. Turn the Red Heater and Compressor Power Switch to *I=ON* position.





11. When the ***Aramark Countertop or Refresh Center*** has reached its Hot Temp Set Point, the heater will cycle off. When the ***Aramark Countertop or Refresh Center*** has reached its Cold Temp Set Point Temperature, the compressor will cycle off.
12. Once the ***Aramark Countertop or Refresh Center*** is at the target temperature(s), sample the water to ensure water meets expectations and additional rinsing or adjustment is not required.
13. Check the ***Aramark Countertop or Refresh Center*** for any leaks. External Leak Protection is always recommended.

## FAULT CODE TROUBLESHOOTING INDEX

1. Red Flashing Light and Audible Alarms are the Leak Detector Alarms for Counter Top Model

### **FAULT CODE: Red Flashing Light and Audible Alarms are the Leak Detector Alarms**

Possible Reason	Solution
Water exiting drip tray due to being full	Empty Drip Tray. Remove Top cover and Front Panel prior to drying out inside of the unit.
Leak in <i>Aramark Countertop or Refresh Center</i>	Water is in the bottom of the unit. Open up unit to determine where the leak is.  Check for source of leak. Dry out inside of unit.



## **POWER TROUBLESHOOTING INDEX**

1. Red Heater and Compressor Power Switch won't light and the Red LED on the Front won't light
2. Red Power Switch is lit but the red LED on the Front is not lit
3. Compressor Runs but does Not Chill
4. Compressor is Not Running

### **1. Red Heater and Compressor Power Switch won't light and the Red LED on the Front won't light**

Possible Reason	Solution
Circuit Breaker	Check the Circuit Breaker
Fuse is Blown	Replace Fuse
Defective / Loose Power Cord	Check that power cord is properly plugged in. If it is properly plugged in, use a different power cord to verify.
Failed Power Line Noise Filter, ElectroMagnetic Interference filter (EMI)	Replace Power Line Noise Filter, ElectroMagnetic Interference filter (EMI)
Defective Red Heater / Compressor Switch	Replace Red Heater / Compressor Switch



## 2. Red Power Switch is lit but the Red LED on the Front is not lit

Possible Reason	Solution
Bad Transformer	Replace Transformer
Black Power Connector to the PCB is not properly connected	Properly connect.
Bad Front PCB	Replace Front
Defective Red Heater / Compressor Switch	Replace Red Heater / Compressor Switch

## 3. Compressor Runs but Does Not Chill

Possible Reason	Solution
Condenser is dirty	Clean the condensing coil of any obstructions or dust.
Reduction of airflow into unit.	Make sure unit is not under minimum ventilation requirements (2 to 4 inches).
Compressor is running very hot.	Low or lost refrigerant. Refrigerant recharge required.

## 4. Compressor is Not Running

Possible Reason	Solution	
Red Heater and Compressor Switch button on unit is in the off position	Turn Red Heater and Compressor Switch on. <i>I = ON</i>	
Compressor Starting Circuit	<p>Turn Red Heater and Compressor Switch off. <i>O = OFF</i>.</p> <p>Remove the compressor cap on side of the compressor;</p> <p>Disconnect the black and red terminal connectors;</p> <p>Inspect the starter and overload relay for any defects.</p> <p>Replace component(s) as needed.</p> <p>Turn Red Heater and Compressor Switch on <i>I = ON</i> and retest compressor operation.</p>	

## **DISPENSING TROUBLESHOOTING INDEX**

1. Dispensing won't stop when not holding the Dispensing Button
2. Water does not dispense from unit
3. Steady Drip out of Faucet
4. Irregular / Intermittent Dispensing
5. Small amount of water periodically dispenses from faucet automatically
6. Low Flow of Water – Rated Service Flow is 1.89 Liters (0.5 gallons) per Minute
7. Hot Water Intermittently Forced Through the Faucet, or a Dual Stream Out of the Faucet
8. Hot Water coming out of both the Faucet and the Vent Hole
9. Hot Water Drip out of Faucet
10. Dispenses Hot and Cold Water at the same time
11. No Cold Water Available
12. Cold Water dispenses from Faucet and Vent Outlet Simultaneously
13. Dispense Buttons stick
14. Run-On Water continues to dispense out of faucet after releasing the dispense button

*Also includes related instruction for Hot Tank Descaling*



## 1. Dispensing Won't Stop when Not Holding the Dispensing Button

Possible Reason	Solution
<p>Too much water pressure.            Recommend 40-60 psi for the <b>Aramark Water Treatment System</b> to operate properly.</p>	<p>The correct input water pressure is critical to the performance of the unit to allow solenoids to open.</p> <p>Check water pressure at the inlet bulkhead with a water pressure gauge.</p> <p>Additional method of verification is to turn off water to unit and press the dispense button. Does the solenoid open without water pressure to the unit? Listen for solenoid to activate, not button "click".</p> <p>Adjust water pressure to 40-60 psi.</p>
<p>Bad Display PCB</p>	<p>Replace Front PCB            Hot and Cold – P/N EN-6085 WLCP PN 12-8103            Cold Only – P/N EN-6086 WLCP PN 12-8615</p>
<p>Debris in the Solenoid</p>	<p>Inspect Solenoid for debris and clean out as needed.</p>
<p>Dispensing Button Stuck</p>	<p>Dirt or Foreign material is filling the gap around the push-buttons. Inspect the push buttons and clean surrounding area. Inspect faucet assembly inside the unit and clean as necessary.</p>

## 2. Water does not dispense from Unit

Possible Reason	Solution
<p>Too much water pressure. Recommend 40-60 psi for the <b>ARAMARK Water Treatment System</b> to operate properly.</p>	<p>The correct input water pressure is critical to the performance of the unit to allow solenoids to open.</p> <p>Check water pressure at the inlet bulkhead with a water pressure gauge.</p> <p>Additional method of verification is to turn off water to unit and press the dispense button. Does the solenoid open without water pressure to the unit? Listen for solenoid to activate, not button “click”.</p> <p>Adjust water pressure to 40-60 psi.</p>
Closed water supply valve	Open the water supply valve.
The unit is not properly plugged into electrical outlet	Check electrical outlet connection, or for blown circuit breaker.
Red Heater and Compressor Switch on unit is in the off position	<p>Turn Red Heater and Compressor switch on. <i>I = ON</i></p> 
15 Amp Fuse Blown	Replace the 15 Amp Fuse as needed.
<p>Water is present in the bottom tray, causing the leak detection to trigger.</p> <p><i>*Leak Detection is on the Counter Top Model only.</i></p>	Remove the Top Cover and Front Panel. Tip the unit slightly to drain, dry bottom tray completely.
Hot and Cold Solenoid connections into the Display PCB are loose.	<p>Turn power off; unplug the unit and visually inspect solenoid connections into the Display PCB. Verify the soldering points on connections are secure into the board.</p> <p>Remove the PCB to inspect the front of the board.</p>
Exhausted Filter	Replace filters as needed.

### 3. Steady Drip Out of Faucet

Possible Reason	Solution
Debris in Solenoid	Inspect Solenoid for debris and clean out as needed.

### 4. Irregular / Intermittent Dispensing

Possible Reason	Solution
Too much water pressure. Recommend 40 to 60 psi for <b>ARAMARK Water Treatment System</b> to operate properly.	<p>Check water pressure at the inlet bulkhead with a water pressure gauge.</p> <p>Additional method of verification is to turn off water to unit and press the dispense button. Does the solenoid open without water pressure to the unit? Listen for solenoid to activate, not button "click".</p> <p>Adjust water pressure to 40-60 psi.</p>
Loose or bad connection on the Front Dispensing PCB or Solenoid Connector	Check that they are connected properly and tightened.
Solenoid	<p>If both the Water Pressure and PCB have been ruled out, then it is the Solenoid.</p> <p>Replace Solenoid.</p>
Dispensing button is broken on PCB	Check PCB for loose or damaged button. Replace PCB as necessary.

### 5. Small Amount of Water Periodically Dispenses from Faucet Automatically

Possible Reason	Solution
Cold or Hot Water Solenoid Valve malfunction`	Inspect valve components for proper function. Replace as necessary.
Obstruction in Solenoid housing is preventing proper sealing of component	<p>Pre-determine whether water being dispensed is Hot / Cold. Isolate the water supply; push the DISPENSE button to release the line pressure, and remove the coil affixed to the Solenoid stem.</p> <p>Remove the stem from the solenoid housing and allow water from the tank to flush out the contaminate(s).</p>

## 6. Low Flow of Water – Rated Service Flow is 1.89 Liters (0.5 gallons) per Minute

Possible Reason	Solution
Determine Flow of Water	Rated Flow Rate is 1.89 Liters (0.5 gallons) per Minute. Check Flow Rate by dispensing into a container for one minute. Measure the amount of water that has been dispensed.
Feed Lines too small	Feed lines can restrict flow if run long distances from the supply. It may be necessary to increase the supply line (e.g. use 3/8" feed line versus 1/4").
Elbows and turns in the feed line	Minimize elbows and turns in the feed line.
Filters	Filters with high pressure drop due to fouling or just by design. Change filters more frequently or go to higher micron size filter for local water conditions.
Restrictions	Flow path to ensure there are no undiscovered restrictions due to debris or malfunctioning valves, including the supply valve at the source.
Booster Pump	Add a booster pump to the supply line if the feed is slower than needed.

## 7. Hot Water Intermittently Forced Out through the Faucet, or a Dual Stream out of the Faucet

Possible Reason	Solution
Mineral deposits on the expansion slot inside the Hot Tank vent chamber which blocks the normal path of water to expand.	Descale the Tank.  <u>See Hot Tank Descaling Instructions that are included further below in this Troubleshoot Section.</u>

## 8. Hot Water Coming out of Faucet Vent Hole

Possible Reason	Solution
<p>Too much water pressure. Recommend 40 to 60 psi for <b>ARAMARK Water Treatment System</b> to operate properly.</p>	<p>Check water pressure at the inlet bulkhead with a water pressure gauge.</p> <p>Additional method of verification is to turn off water to unit and press the dispense button. Does the solenoid open without water pressure to the unit? Listen for solenoid to activate, not button “click”.</p> <p>Adjust water pressure to 40-60 psi.</p>
<p>Improper tubing attachment from the tank to faucet or vice versa.</p>	<p>Verify tubing is connected properly from tank outlets to correct faucet attachments.</p>
<p>Hot Tank outlet hole is scaled over.</p>	<p>Inspect and Descale Tank as needed.</p> <p><b><u>See Hot Tank Descaling Instructions that are included further below in this Troubleshooting Section.</u></b></p> <p>See instructional video on the Partner Area of the Waterlogic.com website for more information.</p>
<p>Expansion chamber is not sealed properly.</p>	<p>Replace the Hot Tank.</p>

## 9. Hot Water Drip out of Faucet

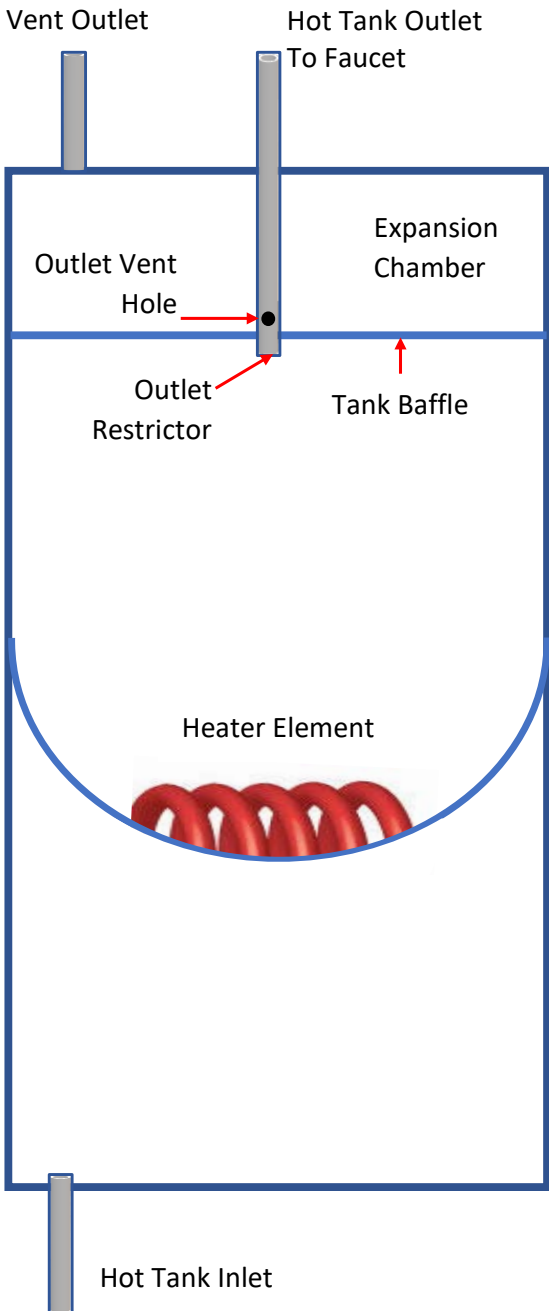
Possible Reason	Solution
<p>Small Outlet Vent Hole susceptible to scale build up.</p>	<p>Descal Tank.</p> <p><b><u>See Hot Tank Descaling Instructions that are included further below in this Troubleshooting Section.</u></b></p> <p>See instructional video on the Partner Area of the Waterlogic.com website for more information.</p>
	<p>All <b>Waterlogic</b> Hot Tanks have a built in Vent or Expansion Chamber in the top of the tank except for WL270 (GF) units.</p> <p>The Vent Chamber allows for expansion of the water when it is heated.</p> <p>The chambers are separated by a welded-in tank baffle.</p> <p>Water always flows into the bottom of the tank and out the top to the faucet.</p> <p>The hot tank outlet tube has a restrictor in its base. This ensures the reservoir is always full by allowing more water in than out.</p> <p>There is a small hole in the side of the tank outlet tube that allows air and water to pass into the vent chamber as it is heated.</p> <p>Water in the vent chamber is suctioned back through the outlet tube vent hole when water is dispensed.</p> <p>Expansion of water as it is heated in the reservoir will push the water out the faucet when the outlet tube vent hole becomes plugged with debris or scale.</p> <p>The small Outlet Vent Hole is susceptible to scale build up and is a key indicator that descaling is required.</p> <p>It is critical to descale the hot tank through the vent line and outlet line on a regular basis to prevent this problem.</p> <p>Descaling through the inlet and/or outlet lines only will not clean the vent chamber and outlet vent hole properly.</p>

## 10. Dispenses Hot and Cold Water at the Same Time

Possible Reason	Solution
<p>Too much water pressure.            Recommend 40 to 60 psi for <b>ARAMARK Water Treatment System</b> to operate properly.</p>	<p>Check water pressure at the inlet bulkhead with a water pressure gauge.</p> <p>Additional method of verification is to turn off water to unit and press the dispense button. Does the solenoid open without water pressure to the unit? Listen for solenoid to activate, not button “click”.</p> <p>Adjust water pressure to 40-60 psi.</p>
<p>Hot or Cold solenoid is stuck open.</p>	<p>Remove Top cover.</p> <p>Check Hot Solenoid: Dispense cold water and visually inspect tubing for water flow from both tanks.</p> <p>Check Cold Solenoid: Disconnect elbow from outlet of cold solenoid. Select hot water and dispense (quickly releasing dispensing button to avoid much water coming out of cold solenoid.</p> <p>Replace solenoid as necessary.</p>



## 11. No Cold Water Available

Possible Reason	Solution
Too much water pressure. Recommend 40 to 60 psi for <b>ARAMARK Water Treatment System</b> to operate properly.	Check water pressure at the inlet bulkhead with a water pressure gauge.  Additional method of verification is to turn off water to unit and press the dispense button. Does the solenoid open without water pressure to the unit? Listen for solenoid to activate, not button “click”.  Adjust water pressure to 40-60 psi.
Closed Water Supply Valve	Open the Water Supply Valve
Cold Water Solenoid Valve malfunction	Inspect the valve components for proper functionality.
Red Heater and Compressor Switch on unit is off.	Turn Red Heater and Compressor Switch on. <i>I = ON</i>
	
Loose connection(s) on the Display PCB	Turn power off; unplug the unit and visually inspect solenoid connections into the Display PCB. Verify the soldering points on connections are secure into the board.  Remove the PCB to inspect the front of the board.
Exhausted Filter	Replace filters as needed.

## 12. Cold Water Dispenses from Faucet and Vent Outlet Simultaneously

Possible Reason	Solution
Improper tubing attachment from the tank to faucet or vice versa	Verify tubing is connected properly from tank outlets to correct faucet attachments.
Scale has formed inside cold tank outlet tube.	Remove cold water outlet tube from tank to faucet. Pour some scale remover into cold tank.
Expansion chamber in Cold Tank is not sealed properly.	Replace Cold Tank.

### **13. Dispense Buttons Stick**

Possible Reason	Solution
Dirt or Foreign material is filling the gap around the push-buttons.	Inspect the push buttons and clean surrounding area. Inspect faucet assembly inside the unit and clean as necessary.

### **14. Run On – Water continues to dispense out of faucet after releasing the dispense button**

Reason																														
<p>“Run On” or “Carry On” is present in all Waterlogic pressure fed units without outlet solenoids.</p> <p>“Run On” is defined is the amount of water that continues to dispense out of the faucet after releasing the dispense button.</p> <p>Run On exists because the tanks pressurize as water is being dispensed. Every Waterlogic tank has an outlet restrictor to ensure the tanks remain full of water and water is controlled as it is released to the faucet. The inlet solenoid controls flow into the tanks. The tanks will “depressurize” once the dispense button is released the inlet solenoid closes. A small amount of water will “Run On” through the faucet as the tank depressurizes to atmospheric conditions.</p> <p>Typical “Run On” is 2-3 seconds.</p> <p><b>“Run On” can be reduced by installing a pressure limiting device.</b></p> <p>The amount of inlet or supply pressure directly impacts the amount of “Run On” as quantified below.</p>																														
<table border="1"> <thead> <tr> <th colspan="5" data-bbox="180 1518 1349 1551">WLCP Lab Testing of Rn On 7-31-2013</th> </tr> <tr> <th data-bbox="180 1560 370 1593">Pressure</th> <th data-bbox="376 1560 618 1593">Pressure</th> <th data-bbox="625 1560 824 1593">Time</th> <th data-bbox="831 1560 1096 1593">Flow Rate</th> <th data-bbox="1102 1560 1344 1593">Run On</th> </tr> <tr> <th data-bbox="180 1602 370 1635">Static PSI</th> <th data-bbox="376 1602 618 1635">Dynamic PSI</th> <th data-bbox="625 1602 824 1635">4 Liters</th> <th data-bbox="831 1602 1096 1635">l/min</th> <th data-bbox="1102 1602 1344 1635">Seconds</th> </tr> </thead> <tbody> <tr> <td data-bbox="180 1644 370 1677">68</td> <td data-bbox="376 1644 618 1677">40</td> <td data-bbox="625 1644 824 1677">61</td> <td data-bbox="831 1644 1096 1677">2.9508197</td> <td data-bbox="1102 1644 1344 1677">3</td> </tr> <tr> <td data-bbox="180 1686 370 1719">50</td> <td data-bbox="376 1686 618 1719">30</td> <td data-bbox="625 1686 824 1719">72</td> <td data-bbox="831 1686 1096 1719">2.5</td> <td data-bbox="1102 1686 1344 1719">2.5</td> </tr> <tr> <td data-bbox="180 1728 370 1761">32</td> <td data-bbox="376 1728 618 1761">20</td> <td data-bbox="625 1728 824 1761">92</td> <td data-bbox="831 1728 1096 1761">1.956217</td> <td data-bbox="1102 1728 1344 1761">2</td> </tr> </tbody> </table> <p data-bbox="180 1770 1349 1837">Pressure measured at inlet line to unit. Static with unit closed. Dynamic with unit dispensing cold water.</p> <p data-bbox="180 1845 1349 1879">No filters were installed in unit.</p>	WLCP Lab Testing of Rn On 7-31-2013					Pressure	Pressure	Time	Flow Rate	Run On	Static PSI	Dynamic PSI	4 Liters	l/min	Seconds	68	40	61	2.9508197	3	50	30	72	2.5	2.5	32	20	92	1.956217	2
WLCP Lab Testing of Rn On 7-31-2013																														
Pressure	Pressure	Time	Flow Rate	Run On																										
Static PSI	Dynamic PSI	4 Liters	l/min	Seconds																										
68	40	61	2.9508197	3																										
50	30	72	2.5	2.5																										
32	20	92	1.956217	2																										

## **HOT TANK DESCALING INSTRUCTIONS**

The hot tank requires removal of mineral deposits (descaling) on a regular basis. Typically descaling should take place every 6 to 12 months to preserve the long-term health of your unit.

Use non-toxic cleaner such as ScaleKleen, DEZCAL, 20% Citric Acid Solution, or Undiluted Vinegar Solution to remove mineral deposits as directed by the manufacturer depending upon filtration and local water conditions.

Descaling is an important process that removes calcium deposits, or scale, that can build up inside a tank over time. Calcium and scale is non-toxic but left unattended will hinder your unit's performance.

**⚠️ WARNING!** ***PERSONAL PROTECTIVE EQUIPMENT REQUIRED.** Always ensure proper ventilation and use rubber or nitrile gloves and eye protection when using chemicals. Refer to Material Safety Data Sheet for specific requirements of each product.*

**⚠️ CAUTION!** ***STAINLESS STEEL TANK DESCALING.** The Hot Tank is made from stainless steel. Ensure descaling solution is compatible with stainless and always flush the unit completely. Dispose in an environmentally safe manner.*

### **Materials Needed:**

- Personal Protective Equipment. Rubber or Nitrile Safety Gloves and Protective Eyewear
  - Phillips Screwdriver
  - Temperature Gauge
  - Water Pitcher or Container to collect water from the faucet
  - 5-gallon container or drain basin
  - Citric Acid Based Cleaner
  - ¼" Plastic Tubing, at least 4 feet in length, and assorted ¼" quick connect fittings
  - Sanitizing Cartridge – an empty Waterlogic Filter with cartridge removed
  - Food Coloring
1. Bypass filters before starting the Descaling Procedure.
  2. Put descaler per directions and 3 drops of food coloring into the descaling cartridge.
  3. Connect descaling cartridge to the inlet water supply and connect to inlet bulkhead fitting on the back of the unit. Turn on Water Supply.
  4. Select Hot Water and depress the Main Dispensing Button on the Front Control Panel until descaling solution (colored water) comes out of the faucet. Container and drain basic will be required to catch water from the faucet.
  5. Turn off water supply and remove sanitizing cartridge from inlet water supply. Reconnect water supply to inlet fitting.

6. Allow descaling solution to remain in the Hot Tank for 15 minutes (length of time may vary depending on water conditions).
7. Place a pitcher, catch basin or other container under the faucet of the **ARAMARK**.
8. Flush the Hot Tank until water runs clear.
9. Once clear Water dispenses from the faucet the Hot Tank has been descaled. Always ensure unit is performing to the customer's satisfaction.
10. Replace Filters.

**⚠ WARNING! HOT WATER.** *The ARAMARK Water Treatment System produces Hot Water up to 87°C (188°F). Water above 52°C (125°F) can cause severe burns or scalding. Hot water should be dispensed carefully into insulated container to avoid injury. Always use insulated and chemically compatible containers and let unit cool down before draining the Hot Tank to avoid injury.*

**⚠ CAUTION! MUST REPLACE HOT TANK 3-5 YEARS DEPENDING ON USAGE.** *The Hot Tank and its controls must be replaced a minimum of every three to five years depending on usage to ensure efficient and dependable operation.*

**⚠ WARNING! REINSTALL ALL PANELS AND COVERS.** *Always reinstall all panels, protective covers, and fasteners after servicing equipment. Failure to do so could result in severe personal injury and will void the certifications and warranty of the equipment.*

## COLD WATER TROUBLESHOOTING INDEX

1. Cold Water is not Cold (41° +/- 5° F)

### 1. Cold Water is not Cold (41° +/- 5° F)

Possible Reason	Solution
No power or refrigeration elements	<p>Check that the Red Heater and Compressor switch is on.</p> <p>Turn Red Heater and Compressor Switch on. <i>I = ON</i></p> 
<p>Tank has run out of cold water.</p> <p><i>Cold tank capacity is 4 liters for Refresh Center and 2 liters for Counter Top.</i></p>	<p>Wait for cold tank to chill water to temperature prior to dispensing more cold water.</p> <p>A greater capacity of <b>Waterlogic</b> Water Systems is available.</p>
Cold Water Thermostat	Check continuity of thermostat with multimeter. Replace thermostat as required.
Refrigerant has run out	Run compressor for at least ten minutes. If condenser is not warm, then refill the refrigerant.
Compressor problem	If Compressor is not running, repair or replacement is needed.

## HOT WATER TROUBLESHOOTING INDEX

### Hot Water Problems

1. Hot Water is not Hot 85 +/- 15°C (185° +/- 5°)

*Also includes related instructions for Resetting the Hot Tank Overload or High Limit Safety*

### Hot Water is not Hot 85 +/- 15°C (185° +/- 5° F)

**NOTE:** The *Aramark Countertop or Refresh Center* does NOT have Sleep or Power Saving Mode and the hot water should be a of 85 +/- 15°C (185° +/- 5° F) under normal operating conditions.

The Hot temperature set point is 85 +/- 15°C (185° +/- 5° F) and is controlled by a thermostat on the side of the tank.

There is a resettable overload or high limit safety above the thermostat on the side of the tank that will trip to prevent damage to the unit if the tank is dry heated (turned on without water in it).

The *Aramark Countertop or Refresh Center* does NOT have Extra Hot capability and the maximum hot temperature is 87°C (189°F).



It typically takes 10 minutes for the 500W to heat the 1.6 Liter of room temperature (ambient) water to the 85°C (185°F) set point.



Possible Reason	Solution
No power to heater elements	<p>Check that the Red Heater and Compressor switch is on.</p> <p>Turn Red Heater and Compressor Switch on. <i>I = ON</i></p> 
Hot Tank Overload Tripped  <i>Overload is a safety feature to ensure the tank does not overheat.</i>	<p>Overload will “click” when pushed. The overload is automatically reset when pressed.</p> <p><b><u>See Resetting the Hot Tank Overload or High Limit Safety Instructions that are included further below in this Troubleshooting Section</u></b></p>
Thermostat or overload “open” on Hot Tank	<p>Turn Power off. Check OHM’s resistance across terminals on each Thermostat and Overload separately.</p> <p>Good components will indicate a closed circuit or zero OHM’s on the meter.</p> <p>Replace components as necessary.</p>

<p>Heating Coil Not Working</p>	<p>Turn Power off; Drain hot tank; Use multi-meter to check heater element for approximately 26 OHM's resistance.</p> <p>Hot Tank must be empty if you are checking for continuity.</p> <p>Replace Hot Tank as necessary.</p>
<p>Loose or improperly connected wire(s) to the Heating Element / Hot Tank.</p>	<p>Visually inspect wire leads going to the hot tank; confirm proper connections to the heating elements.</p> <p>Hot tank life is 3-5 years, depending on usage.</p> <p><i>*Typically, dealers swap out the Hot Tank at site, take back to the shop to repair.</i></p>

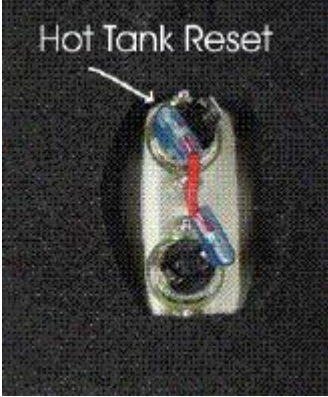

## RESETTING THE HOT TANK OVERLOAD OR HIGH LIMIT SAFETY

1.	<p>Red Heater and Compressor Switch must be in the OFF position</p> <p><i>O=OFF</i></p>	
2.	<p>Unplug the Power Cord from rear of <b>ARAMARK COUNTERTOP AND REFRESH CENTERS .</b></p>	
3.	<p>Refresh Center Model: Remove the <u>Lower Front Panel</u> by removing the Phillips Head Screws underneath the Lower Front Panel.</p> <p>Counter Top Model: Remove the <u>Side Panel</u> by removing Phillips Head Screws from Side Panel.</p>	
4.	<p>Locate the protective metal box on the rear of the Hot Tank.</p> <p>As you look through the condenser coils on the rear of the unit, you will see the Hot Tank located on the right-hand side.</p>	
5.	<p>Reach up behind the Hot Tank and take hold of the Protective Metal Box covering the Thermostat and Overload on the Hot Tank.</p> <p>There are nuts that secure the metal box to the Hot Tank. However, the nuts are loose enough to allow you to remove the metal box.</p> <p>If the nuts on the metal box are too tight, loosen the nuts securing the Hot Tank to the upper base of the unit and lower the hot tank so you can remove the metal box.</p> <p><i>For demonstrative purposes, photos below have lowered the Hot Tank from the unit.</i></p>	

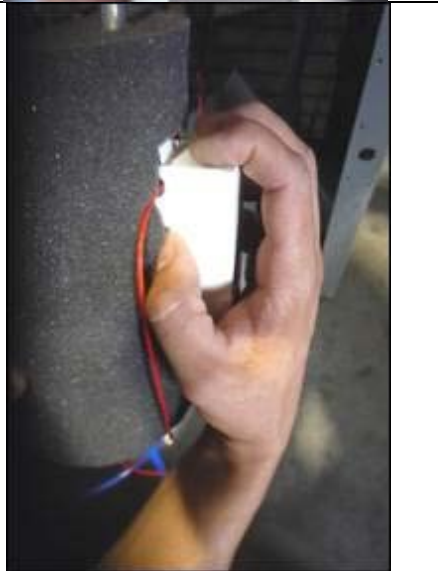
<p>6.</p>	<p>Press the reset button</p>  <p>The image shows a small, rectangular metal component with two circular buttons. The top button is blue and the bottom button is red. A white arrow points to the blue button. The text 'Hot Tank Reset' is printed above the buttons.</p>	 <p>A close-up photograph showing a person's hand pressing the blue reset button on the metal component. The component is mounted on a dark, cylindrical surface.</p>
<p>7.</p>	<p>Reattach the metal box by depressing the top flap of the Metal Box so it snaps back into its original position on the Hot Tank.</p>	 <p>A close-up photograph showing a person's hand holding the metal box and snapping it back into its original position on the hot tank. The box is white and has a top flap that is being depressed.</p>
<p>8.</p>	<p>Replace Panel on unit using Phillips head screws.</p>	
<p>9.</p>	<p>Plug in the Power Cord.</p>	
<p>10</p>	<p>Make sure the Hot and Cold Tanks are filled with water BEFORE turning on the Red Heater and Compressor Switch.</p> <p>Verify the cooler is fully operational before installing it at the customers' site.</p>	